

ALLIANT ENGINEERING, INC.

733 S Marquette Ave #700, Minneapolis, MN 55402

Intersection: TH 65 & 44th Avenue
 Date: 1/16/2025
 Duration: 0600-1900

Site Code: 135
 Ref Pt: N/A
 Page No: 1 of 4

All Vehicles (Cars & Trucks) Printed

Start Time	TH 65 Southbound						44th Avenue Westbound						TH 65 Northbound						44th Avenue Eastbound						Int. Veh. Total	Int. Bike Total
	U-Turn	Left	Thru	Right	App. Total	Peds/Bikes	U-Turn	Left	Thru	Right	App. Total	Peds/Bikes	U-Turn	Left	Thru	Right	App. Total	Peds/Bikes	U-Turn	Left	Thru	Right	App. Total	Peds/Bikes		
6:00	--	3	46	1	50	--	--	3	2	4	9	--	--	4	47	--	51	--	--	3	2	6	11	--	121	--
6:15	--	5	61	4	70	--	--	--	4	7	11	--	--	1	65	--	66	--	--	2	2	6	10	--	157	--
6:30	--	8	66	7	81	--	--	2	6	8	16	--	--	3	66	1	70	--	--	7	1	10	18	--	185	--
6:45	--	7	72	11	90	1	--	2	12	14	28	--	--	5	71	--	76	--	--	8	7	9	24	--	218	1
Hour Total	--	23	245	23	291	1	--	7	24	33	64	--	--	13	249	1	263	--	--	20	12	31	63	--	681	1
7:00	--	5	90	13	108	--	--	6	7	12	25	--	--	9	73	4	86	--	--	10	5	8	23	--	242	--
7:15	--	6	120	11	137	--	--	12	9	7	28	--	--	5	110	5	120	--	--	17	10	9	36	--	321	--
7:30	1	11	141	10	163	3	--	8	12	16	36	--	--	4	123	3	130	--	--	25	6	14	45	--	374	3
7:45	1	9	176	23	209	--	--	6	14	17	37	2	--	9	137	4	150	1	--	25	14	14	53	1	449	4
Hour Total	2	31	527	57	617	3	--	32	42	52	126	2	--	27	443	16	486	1	--	77	35	45	157	1	1386	7
8:00	2	9	162	21	194	--	--	9	24	13	46	--	--	12	112	4	128	--	--	23	11	13	47	1	415	1
8:15	1	6	162	21	190	--	--	5	13	15	33	1	--	12	100	4	116	1	--	10	11	11	32	2	371	4
8:30	3	7	133	6	149	1	--	6	20	16	42	2	--	8	110	1	119	--	--	9	7	14	30	--	340	3
8:45	2	10	124	7	143	1	1	4	12	14	31	1	1	10	116	7	134	--	--	14	6	9	29	1	337	3
Hour Total	8	32	581	55	676	2	1	24	69	58	152	4	1	42	438	16	497	1	--	56	35	47	138	4	1463	11
9:00	2	8	103	6	119	2	--	3	10	16	29	--	--	7	102	9	118	--	--	13	5	11	29	1	295	3
9:15	9	14	121	6	150	--	--	11	7	11	29	2	--	6	125	6	137	--	--	9	7	8	24	--	340	2
9:30	1	8	133	9	151	2	--	6	10	22	38	2	--	5	138	8	151	1	--	6	6	11	23	1	363	6
9:45	4	8	120	7	139	--	--	6	5	16	27	2	1	13	110	5	129	--	--	11	9	8	28	--	323	2
Hour Total	16	38	477	28	559	4	--	26	32	65	123	6	1	31	475	28	535	1	--	39	27	38	104	2	1321	13
10:00	3	7	141	9	160	--	--	3	9	15	27	--	--	6	113	6	125	--	--	17	6	5	28	--	340	--
10:15	3	7	144	10	164	--	--	5	10	20	35	--	--	9	119	4	132	--	--	12	4	9	25	--	356	--
10:30	6	8	132	6	152	--	--	10	3	14	27	1	--	8	126	5	139	1	--	17	7	11	35	1	353	3
10:45	6	14	147	8	175	1	--	7	15	23	45	2	2	12	130	5	149	--	--	16	11	8	35	2	404	5
Hour Total	18	36	564	33	651	1	--	25	37	72	134	3	2	35	488	20	545	1	--	62	28	33	123	3	1453	8
11:00	3	7	127	8	145	1	--	8	6	24	38	2	2	7	136	8	153	--	--	21	6	12	39	3	375	6
11:15	6	14	140	7	167	2	--	7	11	22	40	1	--	7	128	8	143	2	--	18	15	17	50	1	400	6
11:30	3	12	153	11	179	1	--	6	6	30	42	--	3	8	130	10	151	--	--	10	10	15	35	1	407	2
11:45	6	14	151	12	183	1	--	13	15	22	50	2	--	14	160	6	180	--	--	23	12	14	49	1	462	4
Hour Total	18	47	571	38	674	5	--	34	38	98	170	5	5	36	554	32	627	2	--	72	43	58	173	6	1644	18
12:00	5	11	174	9	199	1	--	4	9	30	43	--	--	6	168	7	181	--	--	18	12	16	46	1	469	2
12:15	3	15	159	8	185	--	--	11	12	32	55	--	1	7	168	5	181	--	--	16	8	21	45	--	466	--
12:30	5	19	138	13	175	1	--	7	16	23	46	1	1	11	191	11	214	--	--	27	14	14	55	--	490	2
12:45	7	13	153	6	179	1	--	7	14	20	41	1	--	13	172	6	191	2	--	23	12	12	47	--	458	4
Hour Total	20	58	624	36	738	3	--	29	51	105	185	2	2	37	699	29	767	2	--	84	46	63	193	1	1883	8
13:00	4	15	145	11	175	--	--	11	13	27	51	1	--	10	154	5	169	1	--	22	12	12	46	--	441	2
13:15	7	14	136	8	165	2	--	6	9	24	39	1	1	18	168	12	199	--	--	24	15	11	50	--	453	3
13:30	7	10	139	10	166	--	--	10	9	23	42	1	1	16	192	4	213	--	--	18	8	21	47	--	468	1
13:45	7	11	138	6	162	--	--	12	13	24	49	--	2	14	217	10	243	--	--	17	15	15	47	2	501	2
Hour Total	25	50	558	35	668	2	--	39	44	98	181	3	4	58	731	31	824	1	--	81	50	59	190	2	1863	8
14:00	10	17	182	8	217	--	--	11	15	25	51	1	--	8	165	7	180	1	--	25	10	12	47	--	495	2
14:15	5	8	155	7	175	--	--	10	19	27	56	1	2	15	181	10	208	--	--	29	22	31	82	--	521	1
14:30	2	18	174	14	208	--	--	14	15	23	52	2	--	11	197	14	222	--	--	40	20	23	83	2	565	4
14:45	2	9	179	15	205	--	--	9	13	30	52	1	--	17	223	5	245	--	--	23	14	18	55	--	557	1
Hour Total	19	52	690	44	805	--	--	44	62	105	211	5	2	51	766	36	855	1	--	117	66	84	267	2	2138	8
15:00	6	22	157	12	197	2	--	9	27	38	74	--	1	10	228	7	246	--	--	24	18	13	55	1	572	3
15:15	6	14	194	24	238	2	--	11	18	30	59	--	--	11	213	7	231	1	--	29	23	25	77	1	605	4
15:30	4	14	199	12	229	3	--	13	10	26	49	1	2	14	200	4	220	--	--	32	29	22	83	3	581	7
15:45	2	16	212	16	246	2	--	13	17	14	44	2	2	14	226	8	250	--	--	25	16	24	65	2	605	6
Hour Total	18	66	762	64	910	9	--	46	72	108	226	3	5	49	867	26	947	1	--	110	86	84	280	7	2363	20
16:00	5	23	168	18	214	--	--	11	17	32	60	1	1	20	196	6	223	--	--	25	21	17	63	--	560	1
16:15	6	17	200	11	234	1	--	9	20	20	49	--	1	22	228	14	265	--	--	27	20	24	71	--	619	1
16:30	5	18	174	18	215	1	--	15	18	29	62	1	--	23	221	11	255	1	--	44	20	25	89	1	621	4
16:45	5	14	195	23	237	2	--	13	21	22	56	3	--	13	245	12	270	2	--	20	21	16	57	2	620	9
Hour Total	21	72	737	70	900	4	--	48	76	103	227	5	2	78	890	43	1013	3	--	116	82	82	28			

ALLIANT ENGINEERING, INC.

733 S Marquette Ave #700, Minneapolis, MN 55402

Intersection: TH 65 & 44th Avenue
 Date: 1/16/2025
 Duration: 0600-1900

Site Code: 135
 Ref Pt: N/A
 Page No: 2 of 4

All Vehicles (Cars & Trucks) Printed

Start Time	TH 65 Southbound						44th Avenue Westbound						TH 65 Northbound						44th Avenue Eastbound						Int. Veh. Total	Int. Ped/Bike Total
	U-Turn	Left	Thru	Right	App. Total	Peds/Bikes	U-Turn	Left	Thru	Right	App. Total	Peds/Bikes	U-Turn	Left	Thru	Right	App. Total	Peds/Bikes	U-Turn	Left	Thru	Right	App. Total	Peds/Bikes		
7:30	1	11	141	10	163	3	--	8	12	16	36	--	--	4	123	3	130	--	--	25	6	14	45	--	374	3
7:45	1	9	176	23	209	--	--	6	14	17	37	2	--	9	137	4	150	1	--	25	14	14	53	1	449	4
8:00	2	9	162	21	194	--	--	9	24	13	46	--	--	12	112	4	128	--	--	23	11	13	47	1	415	1
8:15	1	6	162	21	190	--	--	5	13	15	33	1	--	12	100	4	116	1	--	10	11	11	32	2	371	4
Hour Total	5	35	641	75	756	3	--	28	63	61	152	3	--	37	472	15	524	2	--	83	42	52	177	4	1609	12
% of App.	0.7%	4.6%	84.8%	9.9%			0.0%	18.4%	41.4%	40.1%			0.0%	7.1%	90.1%	2.9%			0.0%	46.9%	23.7%	29.4%				
% of Total	0.3%	2.2%	39.8%	4.7%	47.0%	25.0%	0.0%	1.7%	3.9%	3.8%	9.4%	25.0%	0.0%	2.3%	29.3%	0.9%	32.6%	16.7%	0.0%	5.2%	2.6%	3.2%	11.0%	33.3%		
Cars Total	5	35	604	72	716	3	--	28	61	59	148	3	--	36	447	14	497	2	--	81	41	50	172	4	1533	12
Cars % of Movement	100%	100%	94.2%	96.0%	94.7%	25.0%	0.0%	100%	96.8%	96.7%	97.4%	25.0%	0.0%	97.3%	94.7%	93.3%	94.8%	16.7%	0.0%	97.6%	97.6%	96.2%	97.2%	33.3%	95.3%	
Trucks Total	--	--	37	3	40	--	--	--	2	2	4	--	--	1	25	1	27	--	--	2	1	2	5	--	76	--
Trucks % of Movement	0.0%	0.0%	5.8%	4.0%	5.3%	--	0.0%	0.0%	3.2%	3.3%	2.6%	--	0.0%	2.7%	5.3%	6.7%	5.2%	--	0.0%	2.4%	2.4%	3.8%	2.8%	--	4.7%	

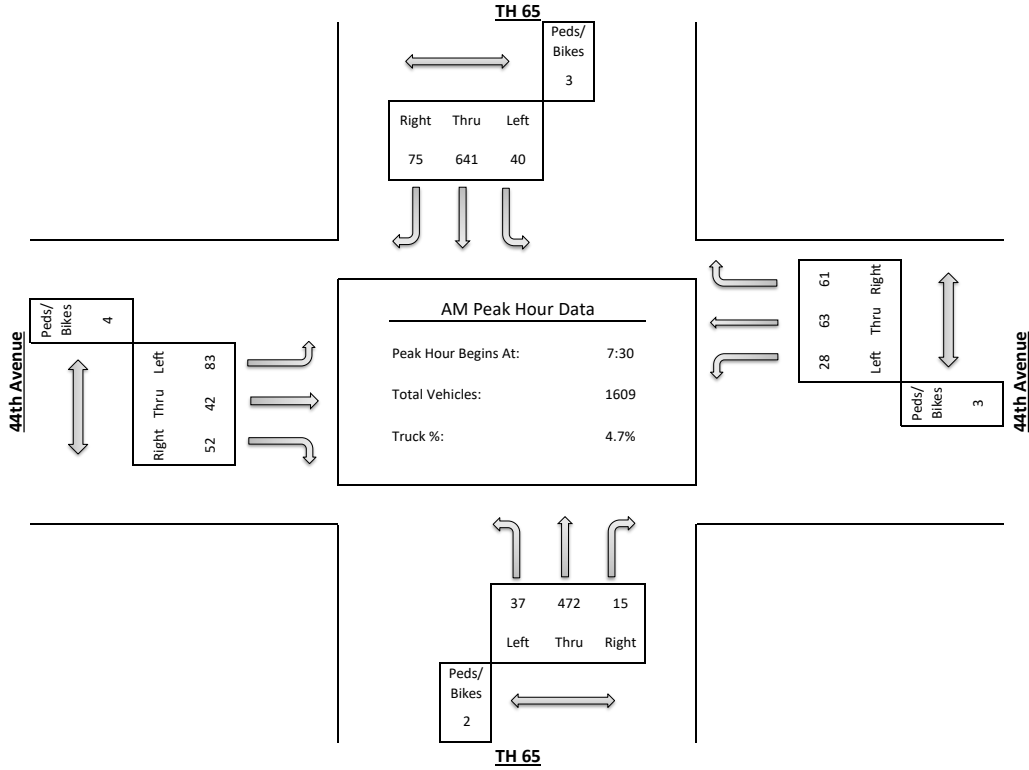

ALLIANT ENGINEERING, INC.

733 S Marquette Ave #700, Minneapolis, MN 55402

Intersection: TH 65 & 44th Avenue
 Date: 1/16/2025
 Duration: 0600-1900

Site Code: 135
 Ref Pt: N/A
 Page No: 3 of 4

All Vehicles (Cars & Trucks) Printed

Start Time	TH 65 Southbound						44th Avenue Westbound						TH 65 Northbound						44th Avenue Eastbound						Int. Veh. Total	Int. Ped/ Bike Total
	U-Turn	Left	Thru	Right	App. Total	Peds/ Bikes	U-Turn	Left	Thru	Right	App. Total	Peds/ Bikes	U-Turn	Left	Thru	Right	App. Total	Peds/ Bikes	U-Turn	Left	Thru	Right	App. Total	Peds/ Bikes		
11:45	6	14	151	12	183	1	--	13	15	22	50	2	--	14	160	6	180	--	--	23	12	14	49	1	462	4
12:00	5	11	174	9	199	1	--	4	9	30	43	--	--	6	168	7	181	--	--	18	12	16	46	1	469	2
12:15	3	15	159	8	185	--	--	11	12	32	55	--	1	7	168	5	181	--	--	16	8	21	45	--	466	--
12:30	5	19	138	13	175	1	--	7	16	23	46	1	1	11	191	11	214	--	--	27	14	14	55	--	490	2
Hour Total	19	59	622	42	742	3	--	35	52	107	194	3	2	38	687	29	756	--	--	84	46	65	195	2	1887	8
% of App.	2.6%	8.0%	83.8%	5.7%			0.0%	18.0%	26.8%	55.2%			0.3%	5.0%	90.9%	3.8%			0.0%	43.1%	23.6%	33.3%				
% of Total	1.0%	3.1%	33.0%	2.2%	39.3%	37.5%	0.0%	1.9%	2.8%	5.7%	10.3%	37.5%	0.1%	2.0%	36.4%	1.5%	40.1%	0.0%	0.0%	4.5%	2.4%	3.4%	10.3%	25.0%		
Cars Total	19	59	602	41	721	3	--	35	51	107	193	3	2	36	668	29	735	--	--	83	46	63	192	2	1841	8
Cars % of Movement	100%	100%	96.8%	97.6%	97.2%	37.5%	0.0%	100%	98.1%	100%	99.5%	37.5%	100%	94.7%	97.2%	100%	97.2%	0.0%	0.0%	98.8%	100%	96.9%	98.5%	25.0%	97.6%	
Trucks Total	--	--	20	1	21	--	--	--	1	--	1	--	--	2	19	--	21	--	--	1	--	2	3	--	46	--
Trucks % of Movement	0.0%	0.0%	3.2%	2.4%	2.8%	--	0.0%	0.0%	1.9%	0.0%	0.5%	--	0.0%	5.3%	2.8%	0.0%	2.8%	--	0.0%	1.2%	0.0%	3.1%	1.5%	--	2.4%	

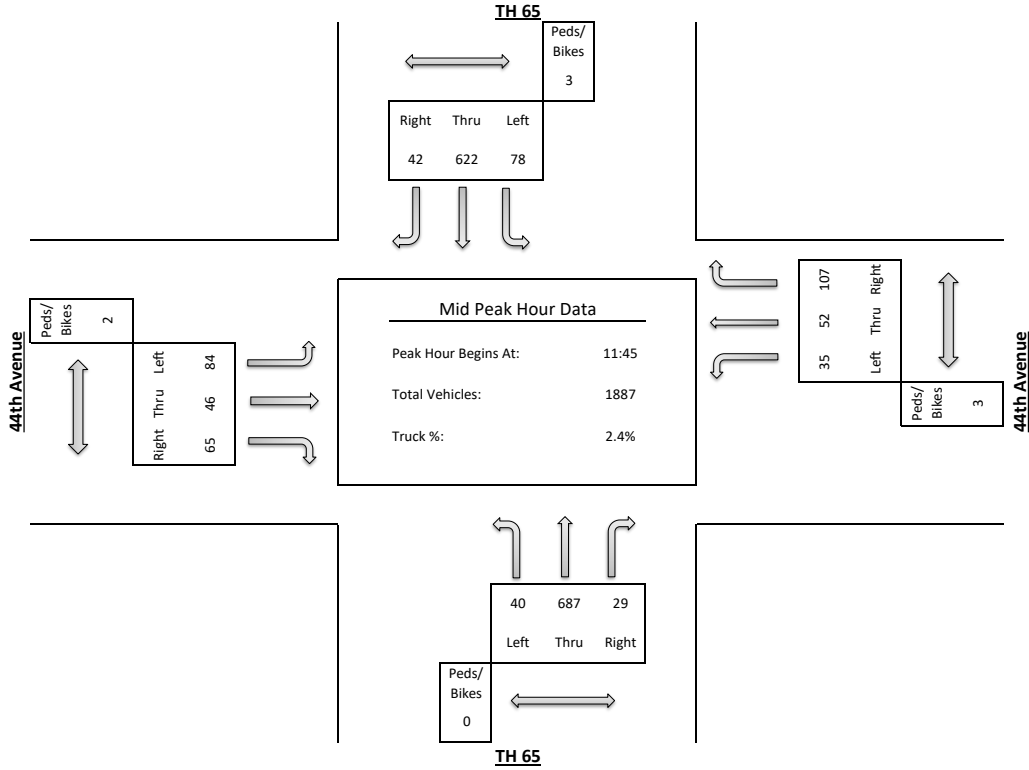

ALLIANT ENGINEERING, INC.

733 S Marquette Ave #700, Minneapolis, MN 55402

Intersection: TH 65 & 44th Avenue
 Date: 1/16/2025
 Duration: 0600-1900

Site Code: 135
 Ref Pt: N/A
 Page No: 4 of 4

All Vehicles (Cars & Trucks) Printed

Start Time	TH 65 Southbound						44th Avenue Westbound						TH 65 Northbound						44th Avenue Eastbound						Int. Veh. Total	Int. Ped/Bike Total
	U-Turn	Left	Thru	Right	App. Total	Peds/Bikes	U-Turn	Left	Thru	Right	App. Total	Peds/Bikes	U-Turn	Left	Thru	Right	App. Total	Peds/Bikes	U-Turn	Left	Thru	Right	App. Total	Peds/Bikes		
16:00	5	23	168	18	214	--	--	11	17	32	60	1	1	20	196	6	223	--	--	25	21	17	63	--	560	1
16:15	6	17	200	11	234	1	--	9	20	20	49	--	1	22	228	14	265	--	--	27	20	24	71	--	619	1
16:30	5	18	174	18	215	1	--	15	18	29	62	1	--	23	221	11	255	1	--	44	20	25	89	1	621	4
16:45	5	14	195	23	237	2	--	13	21	22	56	3	--	13	245	12	270	2	--	20	21	16	57	2	620	9
Hour Total	21	72	737	70	900	4	--	48	76	103	227	5	2	78	890	43	1013	3	--	116	82	82	280	3	2420	15
% of App.	2.3%	8.0%	81.9%	7.8%			0.0%	21.1%	33.5%	45.4%			0.2%	7.7%	87.9%	4.2%			0.0%	41.4%	29.3%	29.3%				
% of Total	0.9%	3.0%	30.5%	2.9%	37.2%	26.7%	0.0%	2.0%	3.1%	4.3%	9.4%	33.3%	0.1%	3.2%	36.8%	1.8%	41.9%	20.0%	0.0%	4.8%	3.4%	3.4%	11.6%	20.0%		
Cars Total	21	70	723	70	884	4	--	48	73	103	224	5	2	77	879	42	1000	3	--	116	81	80	277	3	2385	15
Cars % of Movement	100%	97.2%	98.1%	100%	98.2%	26.7%	0.0%	100%	96.1%	100%	98.7%	33.3%	100%	98.7%	98.8%	97.7%	98.7%	20.0%	0.0%	100%	98.8%	97.6%	98.9%	20.0%	98.6%	
Trucks Total	--	2	14	--	16	--	--	--	3	--	3	--	--	1	11	1	13	--	--	--	1	2	3	--	35	--
Trucks % of Movement	0.0%	2.8%	1.9%	0.0%	1.8%	--	0.0%	0.0%	3.9%	0.0%	1.3%	--	0.0%	1.3%	1.2%	2.3%	1.3%	--	0.0%	0.0%	1.2%	2.4%	1.1%	--	1.4%	

