



# MINNESOTA DEPT OF TRANSPORTATION

## TRAFFIC DATA COLLECTION - METRO

Location: I-35W SB RAMP AT W 76TH ST.

Ref.Pt.: 008.991

JAMAR# 632 DR

TURN MOVEMENT COUNT

File Name : Not Named 1

Site Code : 00000000

Start Date : 2/12/2008

Page No : 1

### Groups Printed- Unshifted

Start Time	35W S EXIT Southbound				W 76TH ST Westbound				35W S EXIT Northbound				W 76TH ST Eastbound				Int. Total
	Left	Thru	Right	Peds	Left	Thru	Right	Peds	Left	Thru	Right	Peds	Left	Thru	Right	Peds	
06:00	8	0	14	0	0	27	0	0	0	0	0	0	0	23	0	0	72
06:15	13	0	20	0	0	38	0	1	0	0	0	0	0	31	0	0	103
06:30	23	0	19	0	0	75	0	0	0	0	0	0	0	59	0	0	176
06:45	36	0	51	0	0	116	0	0	0	0	0	0	0	79	0	1	283
Total	80	0	104	0	0	256	0	1	0	0	0	0	0	192	0	1	634
07:00	20	0	51	0	0	158	0	2	0	0	0	0	0	85	0	1	317
07:15	37	0	92	0	0	192	0	0	0	0	0	0	0	120	0	0	441
07:30	31	0	114	0	0	276	0	0	0	0	0	0	0	125	0	1	547
07:45	71	0	137	0	0	374	0	1	0	0	0	0	0	217	0	1	801
Total	159	0	394	0	0	1000	0	3	0	0	0	0	0	547	0	3	2106
08:00	66	0	127	0	0	287	0	1	0	0	0	0	0	136	0	0	617
08:15	66	0	134	0	0	204	0	0	0	0	0	0	0	112	0	1	517
08:30	58	0	119	0	0	187	0	0	0	0	0	0	0	100	0	0	464
08:45	52	0	97	0	0	182	0	0	0	0	0	0	0	84	0	0	415
Total	242	0	477	0	0	860	0	1	0	0	0	0	0	432	0	1	2013
*** BREAK ***																	
15:00	36	0	34	3	0	112	0	0	0	0	0	0	0	168	0	0	353
15:15	35	0	35	1	0	99	0	0	0	0	0	0	0	185	0	0	355
15:30	40	0	40	2	0	121	0	0	0	0	0	0	0	210	0	0	413
15:45	45	0	25	1	0	149	0	0	0	0	0	0	0	214	0	0	434
Total	156	0	134	7	0	481	0	0	0	0	0	0	0	777	0	0	1555
16:00	36	0	31	1	0	130	0	0	0	0	0	0	0	290	0	0	488
16:15	37	0	50	1	0	131	0	0	0	0	0	0	0	307	0	0	526
16:30	39	0	47	0	0	144	0	0	0	0	0	0	0	388	0	0	618
16:45	49	0	42	0	0	195	0	0	0	0	0	0	0	419	0	0	705
Total	161	0	170	2	0	600	0	0	0	0	0	0	0	1404	0	0	2337
17:00	44	0	42	0	0	270	0	0	0	0	0	0	0	451	0	0	807
17:15	55	0	39	0	0	272	0	0	0	0	0	0	0	525	0	0	891
17:30	45	0	48	0	0	285	0	0	0	0	0	0	0	427	0	0	805
17:45	33	0	49	0	0	232	0	0	0	0	0	0	0	340	0	0	654
Total	177	0	178	0	0	1059	0	0	0	0	0	0	0	1743	0	0	3157
Grand Total	975	0	1457	9	0	4256	0	5	0	0	0	0	0	5095	0	5	11802
Apprch %	39.9	0	59.7	0.4	0	99.9	0	0.1	0	0	0	0	0	99.9	0	0.1	
Total %	8.3	0	12.3	0.1	0	36.1	0	0	0	0	0	0	0	43.2	0	0	



# MINNESOTA DEPT OF TRANSPORTATION

## TRAFFIC DATA COLLECTION - METRO

Location: I-35W SB RAMP AT W 76TH ST.

Ref.Pt.: 008.991

JAMAR# 632 DR

TURN MOVEMENT COUNT

File Name : Not Named 1

Site Code : 00000000

Start Date : 2/12/2008

Page No : 2

Start Time	35W S EXIT Southbound					W 76TH ST Westbound					35W S EXIT Northbound					W 76TH ST Eastbound					Int. Total
	Left	Thru	Right	Peds	App. Total	Left	Thru	Right	Peds	App. Total	Left	Thru	Right	Peds	App. Total	Left	Thru	Right	Peds	App. Total	
<b>Peak Hour Analysis From 06:00 to 08:45 - Peak 1 of 1</b>																					
Peak Hour for Entire Intersection Begins at 07:30																					
07:30	31	0	114	0	145	0	276	0	0	276	0	0	0	0	0	0	125	0	1	126	547
07:45	71	0	137	0	208	0	374	0	1	375	0	0	0	0	0	0	217	0	1	218	801
08:00	66	0	127	0	193	0	287	0	1	288	0	0	0	0	0	0	136	0	0	136	617
08:15	66	0	134	0	200	0	204	0	0	204	0	0	0	0	0	0	112	0	1	113	517
Total Volume	234	0	512	0	746	0	1141	0	2	1143	0	0	0	0	0	0	590	0	3	593	2482
% App. Total	31.4	0	68.6	0		0	99.8	0	0.2		0	0	0	0		0	99.5	0	0.5		
PHF	.824	.000	.934	.000	.897	.000	.763	.000	.500	.762	.000	.000	.000	.000	.000	.000	.680	.000	.750	.680	.775

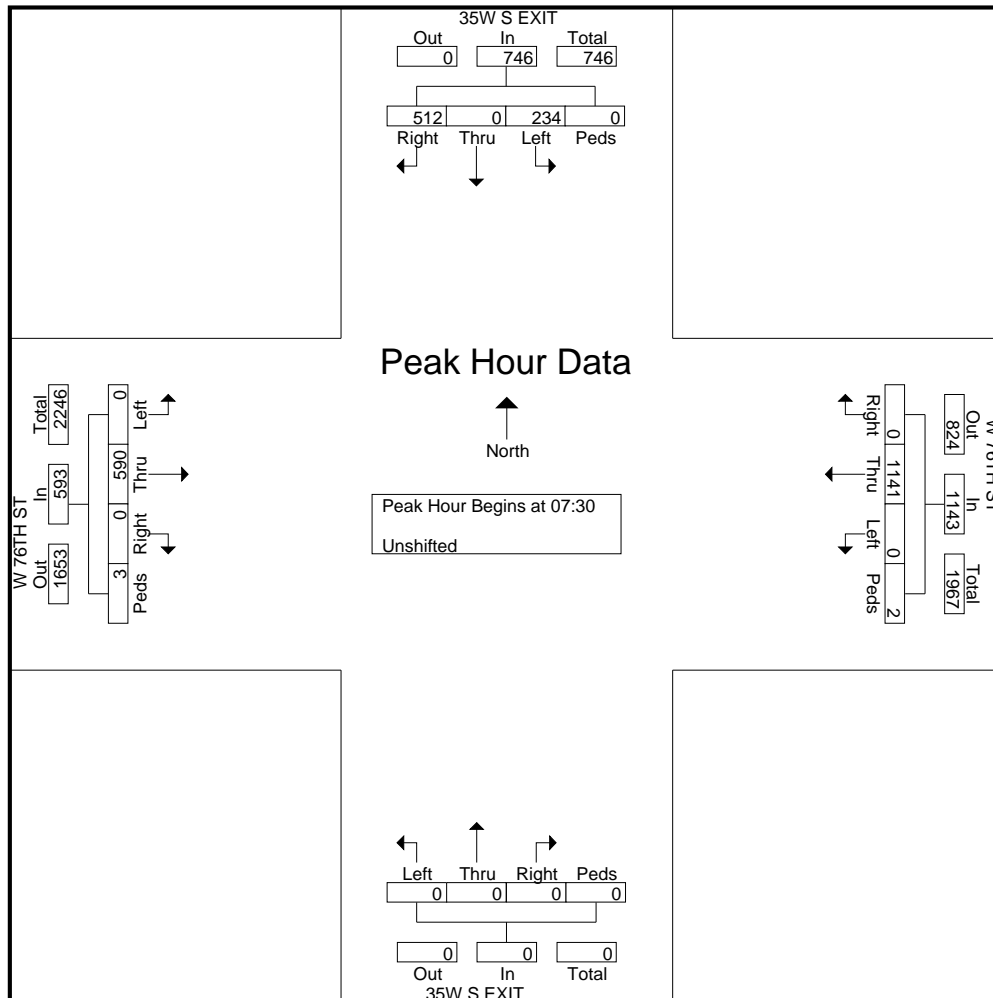



# MINNESOTA DEPT OF TRANSPORTATION

## TRAFFIC DATA COLLECTION - METRO

Location: I-35W SB RAMP AT W 76TH ST.  
 Ref.Pt.: 008.991  
 JAMAR# 632 DR  
 TURN MOVEMENT COUNT

File Name : Not Named 1  
 Site Code : 00000000  
 Start Date : 2/12/2008  
 Page No : 3

Start Time	35W S EXIT Southbound					W 76TH ST Westbound					35W S EXIT Northbound					W 76TH ST Eastbound					Int. Total
	Left	Thru	Right	Peds	App. Total	Left	Thru	Right	Peds	App. Total	Left	Thru	Right	Peds	App. Total	Left	Thru	Right	Peds	App. Total	
<b>Peak Hour Analysis From 15:00 to 17:45 - Peak 1 of 1</b>																					
Peak Hour for Entire Intersection Begins at 16:45																					
16:45	49	0	42	0	91	0	195	0	0	195	0	0	0	0	0	0	419	0	0	419	705
17:00	44	0	42	0	86	0	270	0	0	270	0	0	0	0	0	0	451	0	0	451	807
17:15	<b>55</b>	0	39	0	<b>94</b>	0	272	0	0	272	0	0	0	0	0	0	<b>525</b>	0	0	<b>525</b>	<b>891</b>
17:30	45	0	<b>48</b>	0	93	0	<b>285</b>	0	0	<b>285</b>	0	0	0	0	0	0	427	0	0	427	805
Total Volume	193	0	171	0	364	0	1022	0	0	1022	0	0	0	0	0	0	1822	0	0	1822	3208
% App. Total	53	0	47	0		0	100	0	0		0	0	0	0		0	100	0	0		
PHF	.877	.000	.891	.000	.968	.000	.896	.000	.000	.896	.000	.000	.000	.000	.000	.000	.868	.000	.000	.868	.900

