

Albeck Gerken, Inc

Transportation Engineers

Traffic Data Collection

Prairie Center Drive at West 78th St.
 Ref.Pt.: Eden Prairie
 Data by: Albeck Gerken Inc - George/Nic
 TURN MOVEMENT COUNT

File Name : Prairie Center Dr at W 78th St 2004
 Site Code : 00000000
 Start Date : 11/30/2004
 Page No : 1

Groups Printed- Unshifted

| Start Time | PRAIRIE CENTER DR. Southbound | | | | WEST 78TH ST Westbound | | | | PRAIRIE CENTER DRIVE Northbound | | | | WEST 78th ST. Eastbound | | | | Int. Total |
|---------------|----------------------------------|------|-------|------|---------------------------|------|-------|------|------------------------------------|------|-------|------|----------------------------|------|-------|------|------------|
| | Left | Thru | Right | Peds | Left | Thru | Right | Peds | Left | Thru | Right | Peds | Left | Thru | Right | Peds | |
| 06:30 | 6 | 42 | 16 | 0 | 7 | 5 | 10 | 0 | 10 | 155 | 19 | 0 | 12 | 15 | 2 | 0 | 299 |
| 06:45 | 14 | 76 | 23 | 0 | 8 | 13 | 12 | 0 | 12 | 178 | 51 | 0 | 13 | 18 | 1 | 0 | 419 |
| Total | 20 | 118 | 39 | 0 | 15 | 18 | 22 | 0 | 22 | 333 | 70 | 0 | 25 | 33 | 3 | 0 | 718 |
| 07:00 | 16 | 64 | 24 | 0 | 10 | 14 | 9 | 0 | 14 | 230 | 89 | 0 | 21 | 17 | 2 | 0 | 510 |
| 07:15 | 30 | 85 | 33 | 0 | 3 | 5 | 7 | 1 | 23 | 230 | 121 | 0 | 24 | 37 | 6 | 0 | 605 |
| 07:30 | 46 | 87 | 25 | 0 | 13 | 17 | 8 | 0 | 16 | 253 | 142 | 0 | 18 | 49 | 9 | 1 | 684 |
| 07:45 | 66 | 97 | 25 | 0 | 15 | 13 | 15 | 0 | 11 | 311 | 131 | 0 | 24 | 55 | 6 | 0 | 769 |
| Total | 158 | 333 | 107 | 0 | 41 | 49 | 39 | 1 | 64 | 1024 | 483 | 0 | 87 | 158 | 23 | 1 | 2568 |
| 08:00 | 37 | 86 | 25 | 0 | 12 | 10 | 14 | 0 | 17 | 252 | 122 | 0 | 24 | 52 | 3 | 0 | 654 |
| 08:15 | 27 | 80 | 29 | 0 | 8 | 10 | 17 | 0 | 16 | 200 | 94 | 0 | 14 | 27 | 5 | 0 | 527 |
| *** BREAK *** | | | | | | | | | | | | | | | | | |
| Total | 64 | 166 | 54 | 0 | 20 | 20 | 31 | 0 | 33 | 452 | 216 | 0 | 38 | 79 | 8 | 0 | 1181 |
| *** BREAK *** | | | | | | | | | | | | | | | | | |
| 16:00 | 28 | 214 | 58 | 0 | 29 | 34 | 21 | 0 | 19 | 133 | 32 | 0 | 29 | 34 | 25 | 0 | 656 |
| 16:15 | 19 | 212 | 75 | 0 | 32 | 30 | 19 | 0 | 24 | 99 | 26 | 0 | 22 | 31 | 35 | 0 | 624 |
| 16:30 | 42 | 251 | 80 | 0 | 54 | 40 | 16 | 0 | 20 | 116 | 32 | 0 | 20 | 34 | 43 | 0 | 748 |
| 16:45 | 39 | 254 | 83 | 0 | 42 | 36 | 18 | 0 | 27 | 117 | 25 | 0 | 24 | 53 | 35 | 0 | 753 |
| Total | 128 | 931 | 296 | 0 | 157 | 140 | 74 | 0 | 90 | 465 | 115 | 0 | 95 | 152 | 138 | 0 | 2781 |
| 17:00 | 38 | 289 | 98 | 0 | 60 | 62 | 23 | 0 | 19 | 113 | 36 | 0 | 25 | 35 | 30 | 0 | 828 |
| 17:15 | 34 | 309 | 110 | 0 | 55 | 44 | 30 | 0 | 30 | 110 | 33 | 0 | 27 | 40 | 43 | 0 | 865 |
| 17:30 | 38 | 277 | 88 | 0 | 46 | 47 | 41 | 0 | 32 | 100 | 28 | 0 | 30 | 40 | 40 | 0 | 807 |
| 17:45 | 16 | 222 | 62 | 0 | 43 | 40 | 20 | 0 | 14 | 87 | 14 | 0 | 28 | 39 | 52 | 0 | 637 |
| Total | 126 | 1097 | 358 | 0 | 204 | 193 | 114 | 0 | 95 | 410 | 111 | 0 | 110 | 154 | 165 | 0 | 3137 |
| Grand Total | 496 | 2645 | 854 | 0 | 437 | 420 | 280 | 1 | 304 | 2684 | 995 | 0 | 355 | 576 | 337 | 1 | 10385 |
| Apprch % | 12.4 | 66.2 | 21.4 | 0 | 38.4 | 36.9 | 24.6 | 0.1 | 7.6 | 67.4 | 25 | 0 | 28 | 45.4 | 26.6 | 0.1 | |
| Total % | 4.8 | 25.5 | 8.2 | 0 | 4.2 | 4 | 2.7 | 0 | 2.9 | 25.8 | 9.6 | 0 | 3.4 | 5.5 | 3.2 | 0 | |

Albeck Gerken, Inc

Transportation Engineers

Traffic Data Collection

Prairie Center Drive at West 78th St.
 Ref.Pt.: Eden Prairie
 Data by: Albeck Gerken Inc - George/Nic
 TURN MOVEMENT COUNT

File Name : Prairie Center Dr at W 78th St 2004
 Site Code : 00000000
 Start Date : 11/30/2004
 Page No : 2

| Start Time | PRAIRIE CENTER DR. Southbound | | | | | WEST 78TH ST Westbound | | | | | PRAIRIE CENTER DRIVE Northbound | | | | | WEST 78th ST. Eastbound | | | | | Int. Total |
|--|----------------------------------|------|-------|------|------------|---------------------------|------|-------|------|------------|------------------------------------|------|-------|------|------------|----------------------------|------|-------|------|------------|------------|
| | Left | Thru | Right | Peds | App. Total | Left | Thru | Right | Peds | App. Total | Left | Thru | Right | Peds | App. Total | Left | Thru | Right | Peds | App. Total | |
| Peak Hour Analysis From 06:30 to 08:15 - Peak 1 of 1 | | | | | | | | | | | | | | | | | | | | | |
| Peak Hour for Entire Intersection Begins at 07:15 | | | | | | | | | | | | | | | | | | | | | |
| 07:15 | 30 | 85 | 33 | 0 | 148 | 3 | 5 | 7 | 1 | 16 | 23 | 230 | 121 | 0 | 374 | 24 | 37 | 6 | 0 | 67 | 605 |
| 07:30 | 46 | 87 | 25 | 0 | 158 | 13 | 17 | 8 | 0 | 38 | 16 | 253 | 142 | 0 | 411 | 18 | 49 | 9 | 1 | 77 | 684 |
| 07:45 | 66 | 97 | 25 | 0 | 188 | 15 | 13 | 15 | 0 | 43 | 11 | 311 | 131 | 0 | 453 | 24 | 55 | 6 | 0 | 85 | 769 |
| 08:00 | 37 | 86 | 25 | 0 | 148 | 12 | 10 | 14 | 0 | 36 | 17 | 252 | 122 | 0 | 391 | 24 | 52 | 3 | 0 | 79 | 654 |
| Total Volume | 179 | 355 | 108 | 0 | 642 | 43 | 45 | 44 | 1 | 133 | 67 | 1046 | 516 | 0 | 1629 | 90 | 193 | 24 | 1 | 308 | 2712 |
| % App. Total | 27.9 | 55.3 | 16.8 | 0 | | 32.3 | 33.8 | 33.1 | 0.8 | | 4.1 | 64.2 | 31.7 | 0 | | 29.2 | 62.7 | 7.8 | 0.3 | | |
| PHF | .678 | .915 | .818 | .000 | .854 | .717 | .662 | .733 | .250 | .773 | .728 | .841 | .908 | .000 | .899 | .938 | .877 | .667 | .250 | .906 | .882 |

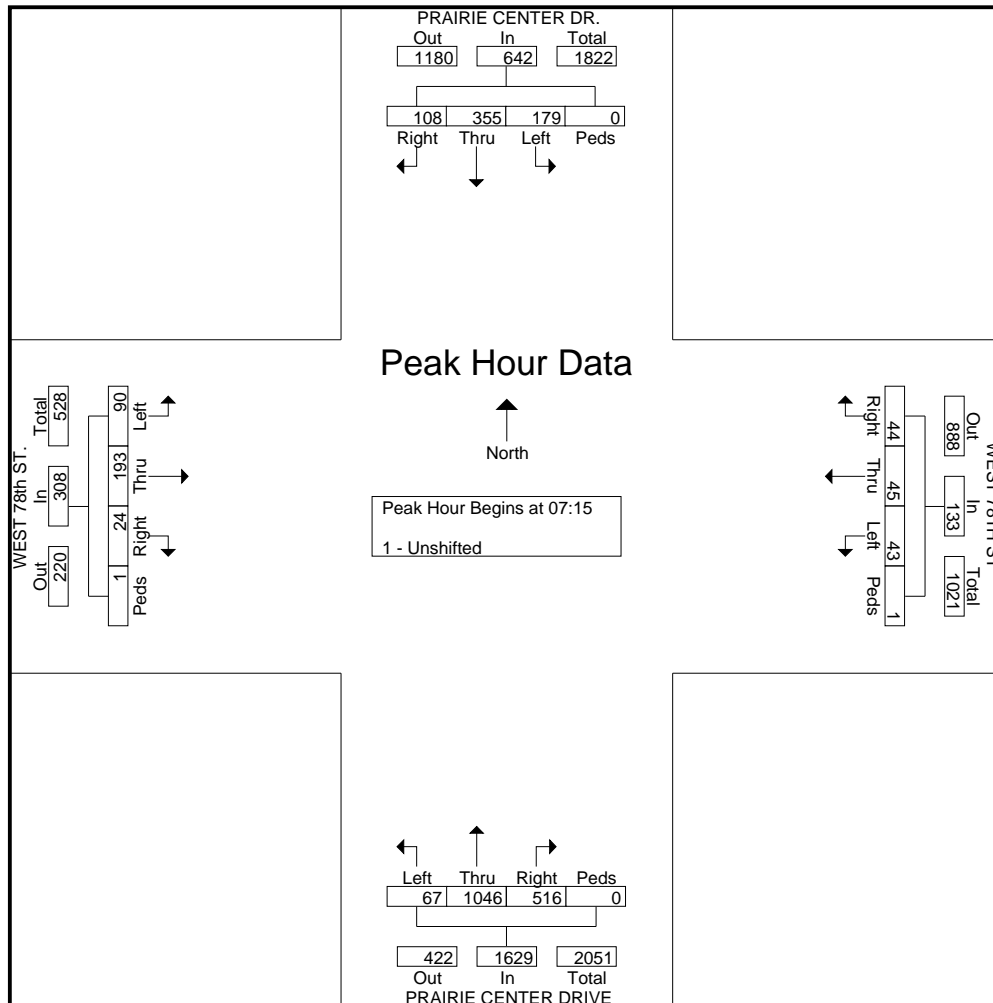

Albeck Gerken, Inc

Transportation Engineers

Traffic Data Collection

Prairie Center Drive at West 78th St.
 Ref.Pt.: Eden Prairie
 Data by: Albeck Gerken Inc - George/Nic
 TURN MOVEMENT COUNT

File Name : Prairie Center Dr at W 78th St 2004
 Site Code : 00000000
 Start Date : 11/30/2004
 Page No : 3

| Start Time | PRAIRIE CENTER DR. Southbound | | | | | WEST 78TH ST Westbound | | | | | PRAIRIE CENTER DRIVE Northbound | | | | | WEST 78th ST. Eastbound | | | | | Int. Total |
|--|-------------------------------|------|-------|------|------------|------------------------|------|-------|------|------------|---------------------------------|------|-------|------|------------|-------------------------|------|-------|------|------------|------------|
| | Left | Thru | Right | Peds | App. Total | Left | Thru | Right | Peds | App. Total | Left | Thru | Right | Peds | App. Total | Left | Thru | Right | Peds | App. Total | |
| Peak Hour Analysis From 16:00 to 17:45 - Peak 1 of 1 | | | | | | | | | | | | | | | | | | | | | |
| Peak Hour for Entire Intersection Begins at 16:45 | | | | | | | | | | | | | | | | | | | | | |
| 16:45 | 39 | 254 | 83 | 0 | 376 | 42 | 36 | 18 | 0 | 96 | 27 | 117 | 25 | 0 | 169 | 24 | 53 | 35 | 0 | 112 | 753 |
| 17:00 | 38 | 289 | 98 | 0 | 425 | 60 | 62 | 23 | 0 | 145 | 19 | 113 | 36 | 0 | 168 | 25 | 35 | 30 | 0 | 90 | 828 |
| 17:15 | 34 | 309 | 110 | 0 | 453 | 55 | 44 | 30 | 0 | 129 | 30 | 110 | 33 | 0 | 173 | 27 | 40 | 43 | 0 | 110 | 865 |
| 17:30 | 38 | 277 | 88 | 0 | 403 | 46 | 47 | 41 | 0 | 134 | 32 | 100 | 28 | 0 | 160 | 30 | 40 | 40 | 0 | 110 | 807 |
| Total Volume | 149 | 1129 | 379 | 0 | 1657 | 203 | 189 | 112 | 0 | 504 | 108 | 440 | 122 | 0 | 670 | 106 | 168 | 148 | 0 | 422 | 3253 |
| % App. Total | 9 | 68.1 | 22.9 | 0 | | 40.3 | 37.5 | 22.2 | 0 | | 16.1 | 65.7 | 18.2 | 0 | | 25.1 | 39.8 | 35.1 | 0 | | |
| PHF | .955 | .913 | .861 | .000 | .914 | .846 | .762 | .683 | .000 | .869 | .844 | .940 | .847 | .000 | .968 | .883 | .792 | .860 | .000 | .942 | .940 |

