

Alliant Engineering Inc Minneapolis, MN 55415

TH-3 at 145th St W ROSEMOUNT
 Ref.Pt.: 033.065
 Alliant Engineering Inc
 TURN MOVEMENT COUNT

File Name : 24_TH 3 at 145th St_022510
 Site Code : 00000024
 Start Date : 2/25/2010
 Page No : 1

Groups Printed- Unshifted - Bank 1

Start Time	Robert Trail S (TH 3) Southbound				145th St W Westbound				Robert Trail S (TH 3) Northbound				145th St W Eastbound				Int. Total
	Left	Thru	Right	Peds	Left	Thru	Right	Peds	Left	Thru	Right	Peds	Left	Thru	Right	Peds	
06:15	4	28	5	0	4	3	9	0	2	75	3	0	13	5	9	0	160
06:30	7	32	3	0	10	4	11	0	3	97	8	0	19	17	4	0	215
06:45	15	37	3	0	8	14	12	0	3	117	13	0	19	23	5	0	269
Total	26	97	11	0	22	21	32	0	8	289	24	0	51	45	18	0	644
07:00	12	57	6	0	10	18	20	0	8	137	4	0	34	15	6	0	327
07:15	12	68	7	0	5	25	27	1	14	163	13	0	23	24	12	1	395
07:30	18	75	12	1	9	25	21	0	10	140	6	0	28	26	14	0	385
07:45	30	75	7	0	10	28	28	0	4	136	15	0	34	27	15	0	409
Total	72	275	32	1	34	96	96	1	36	576	38	0	119	92	47	1	1516
08:00	14	50	3	0	16	15	19	0	7	105	13	0	12	24	12	0	290
08:15	16	50	9	0	16	13	9	0	5	90	11	0	18	22	7	0	266
08:30	12	30	3	0	9	13	14	0	4	84	7	0	6	12	13	0	207
08:45	14	48	6	0	12	6	8	0	5	71	8	0	13	6	9	0	206
Total	56	178	21	0	53	47	50	0	21	350	39	0	49	64	41	0	969
09:00	13	60	12	0	12	29	13	0	4	84	11	0	10	10	15	0	273
09:15	6	79	13	0	11	21	8	0	5	54	7	0	11	15	18	0	248
*** BREAK ***																	
Total	19	139	25	0	23	50	21	0	9	138	18	0	21	25	33	0	521
*** BREAK ***																	
10:30	2	46	11	0	8	10	6	1	10	56	8	0	14	10	9	0	191
10:45	6	48	8	0	8	9	4	0	7	42	12	0	14	8	12	0	178
Total	8	94	19	0	16	19	10	1	17	98	20	0	28	18	21	0	369
11:00	7	44	6	0	8	13	7	0	7	53	16	0	3	10	10	0	184
11:15	13	66	10	0	8	19	10	0	10	39	18	0	5	10	18	0	226
11:30	8	68	13	0	15	16	12	0	12	50	14	0	9	19	12	0	248
11:45	6	56	13	0	10	20	6	0	10	53	15	0	13	12	13	0	227
Total	34	234	42	0	41	68	35	0	39	195	63	0	30	51	53	0	885
12:00	9	69	3	0	18	20	11	0	5	77	17	0	12	22	11	0	274
12:15	8	72	7	0	12	9	8	0	15	59	13	0	11	13	15	0	242
12:30	7	75	10	0	6	11	6	0	10	63	17	0	9	9	14	0	237
12:45	8	76	10	0	15	20	5	0	6	63	9	0	12	11	9	0	244
Total	32	292	30	0	51	60	30	0	36	262	56	0	44	55	49	0	997
13:00	3	68	9	0	10	18	8	0	9	77	12	0	3	10	23	0	250
13:15	10	61	8	0	9	9	10	0	7	73	9	0	11	11	16	0	234
*** BREAK ***																	
Total	13	129	17	0	19	27	18	0	16	150	21	0	14	21	39	0	484
*** BREAK ***																	
14:30	14	104	22	0	12	15	17	0	15	75	18	0	18	27	22	0	359
14:45	10	73	9	0	12	16	14	0	7	78	15	1	16	17	15	0	283
Total	24	177	31	0	24	31	31	0	22	153	33	1	34	44	37	0	642
15:00	19	115	19	0	25	22	19	1	15	67	14	0	22	19	15	0	372
15:15	10	91	22	1	16	33	12	1	7	67	19	0	14	23	22	6	344
15:30	8	109	12	0	24	29	15	0	13	65	20	1	28	14	24	3	365
15:45	14	140	11	0	21	27	11	0	5	80	17	0	18	26	14	0	384
Total	51	455	64	1	86	111	57	2	40	279	70	1	82	82	75	9	1465
16:00	14	120	14	3	12	13	19	0	3	78	10	0	17	19	22	0	344

Alliant Engineering Inc Minneapolis, MN 55415

TH-3 at 145th St W ROSEMOUNT
 Ref.Pt.: 033.065
 Alliant Engineering Inc
 TURN MOVEMENT COUNT

File Name : 24_TH 3 at 145th St_022510
 Site Code : 00000024
 Start Date : 2/25/2010
 Page No : 2

Groups Printed- Unshifted - Bank 1

Start Time	Robert Trail S (TH 3) Southbound				145th St W Westbound				Robert Trail S (TH 3) Northbound				145th St W Eastbound				Int. Total
	Left	Thru	Right	Peds	Left	Thru	Right	Peds	Left	Thru	Right	Peds	Left	Thru	Right	Peds	
16:15	11	150	14	3	22	44	7	1	12	91	20	1	12	24	12	2	426
16:30	14	146	16	3	19	46	12	0	9	76	14	0	22	32	20	0	429
16:45	20	164	22	0	14	33	27	0	8	100	9	1	22	22	22	0	464
Total	59	580	66	9	67	136	65	1	32	345	53	2	73	97	76	2	1663
17:00	28	163	21	1	25	30	20	1	7	109	21	1	9	24	15	0	475
17:15	17	152	12	1	14	30	15	0	10	80	10	2	19	18	14	0	394
17:30	18	152	15	0	21	26	6	0	14	90	9	0	18	24	17	0	410
17:45	21	129	20	1	15	30	16	0	9	110	10	0	14	20	17	0	412
Total	84	596	68	3	75	116	57	1	40	389	50	3	60	86	63	0	1691
Grand Total	478	3246	426	14	511	782	502	6	316	3224	485	7	605	680	552	12	11846
Apprch %	11.5	78	10.2	0.3	28.4	43.4	27.9	0.3	7.8	80	12	0.2	32.7	36.8	29.9	0.6	
Total %	4	27.4	3.6	0.1	4.3	6.6	4.2	0.1	2.7	27.2	4.1	0.1	5.1	5.7	4.7	0.1	
Unshifted	460	3099	416	14	500	733	478	6	308	3087	466	7	574	631	533	12	11324
% Unshifted	96.2	95.5	97.7	100	97.8	93.7	95.2	100	97.5	95.8	96.1	100	94.9	92.8	96.6	100	95.6
Bank 1	18	147	10	0	11	49	24	0	8	137	19	0	31	49	19	0	522
% Bank 1	3.8	4.5	2.3	0	2.2	6.3	4.8	0	2.5	4.2	3.9	0	5.1	7.2	3.4	0	4.4

Alliant Engineering Inc Minneapolis, MN 55415

TH-3 at 145th St W ROSEMOUNT
 Ref.Pt.: 033.065
 Alliant Engineering Inc
 TURN MOVEMENT COUNT

File Name : 24_TH 3 at 145th St_022510
 Site Code : 00000024
 Start Date : 2/25/2010
 Page No : 3

Start Time	Robert Trail S (TH 3) Southbound					145th St W Westbound					Robert Trail S (TH 3) Northbound					145th St W Eastbound					Int. Total
	Left	Thru	Right	Peds	App. Total	Left	Thru	Right	Peds	App. Total	Left	Thru	Right	Peds	App. Total	Left	Thru	Right	Peds	App. Total	
Peak Hour Analysis From 06:15 to 09:15 - Peak 1 of 1																					
Peak Hour for Entire Intersection Begins at 07:00																					
07:00	12	57	6	0	75	10	18	20	0	48	8	137	4	0	149	34	15	6	0	55	327
07:15	12	68	7	0	87	5	25	27	1	58	14	163	13	0	190	23	24	12	1	60	395
07:30	18	75	12	1	106	9	25	21	0	55	10	140	6	0	156	28	26	14	0	68	385
07:45	30	75	7	0	112	10	28	28	0	66	4	136	15	0	155	34	27	15	0	76	409
Total Volume	72	275	32	1	380	34	96	96	1	227	36	576	38	0	650	119	92	47	1	259	1516
% App. Total	18.9	72.4	8.4	0.3		15	42.3	42.3	0.4		5.5	88.6	5.8	0		45.9	35.5	18.1	0.4		
PHF	.600	.917	.667	.250	.848	.850	.857	.857	.250	.860	.643	.883	.633	.000	.855	.875	.852	.783	.250	.852	.927

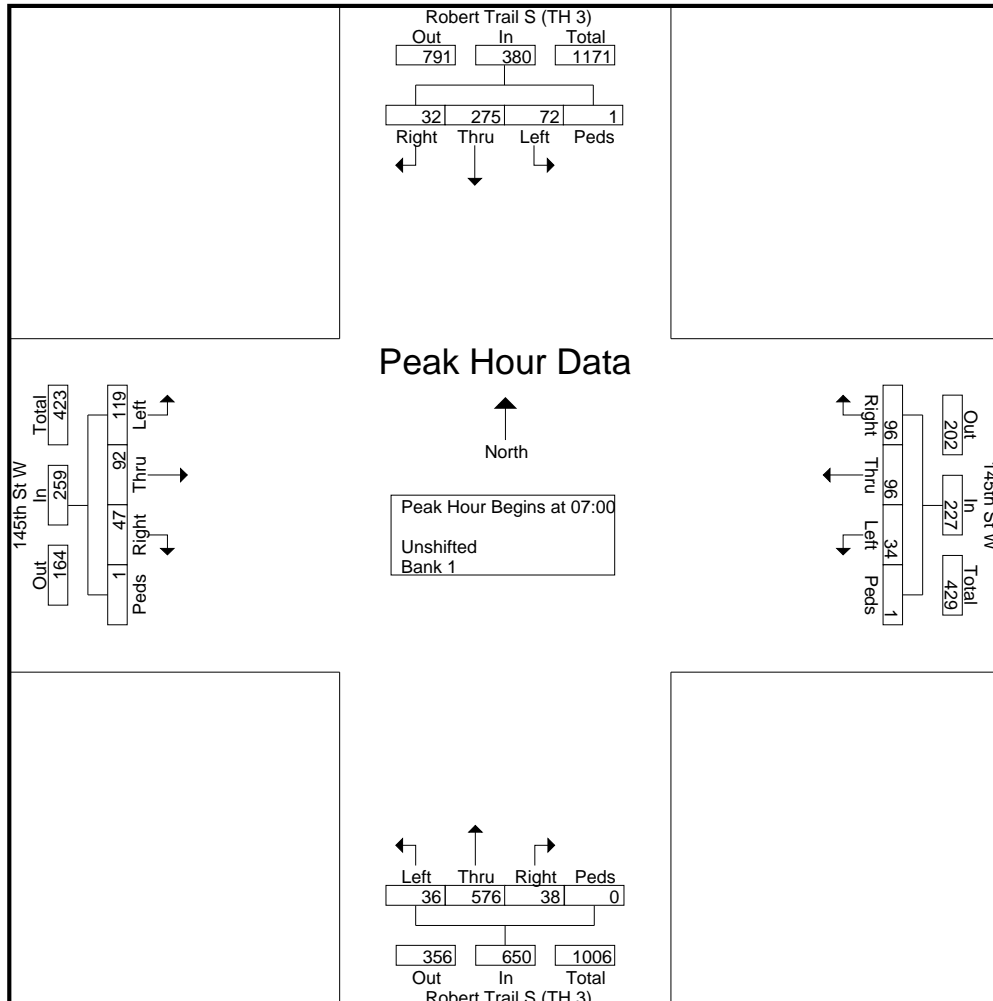

Alliant Engineering Inc Minneapolis, MN 55415

TH-3 at 145th St W ROSEMOUNT
 Ref.Pt.: 033.065
 Alliant Engineering Inc
 TURN MOVEMENT COUNT

File Name : 24_TH 3 at 145th St_022510
 Site Code : 00000024
 Start Date : 2/25/2010
 Page No : 4

Start Time	Robert Trail S (TH 3) Southbound					145th St W Westbound					Robert Trail S (TH 3) Northbound					145th St W Eastbound					Int. Total
	Left	Thru	Right	Peds	App. Total	Left	Thru	Right	Peds	App. Total	Left	Thru	Right	Peds	App. Total	Left	Thru	Right	Peds	App. Total	
Peak Hour Analysis From 15:00 to 17:45 - Peak 1 of 1																					
Peak Hour for Entire Intersection Begins at 16:15																					
16:15	11	150	14	3	178	22	44	7	1	74	12	91	20	1	124	12	24	12	2	50	426
16:30	14	146	16	3	179	19	46	12	0	77	9	76	14	0	99	22	32	20	0	74	429
16:45	20	164	22	0	206	14	33	27	0	74	8	100	9	1	118	22	22	22	0	66	464
17:00	28	163	21	1	213	25	30	20	1	76	7	109	21	1	138	9	24	15	0	48	475
Total Volume	73	623	73	7	776	80	153	66	2	301	36	376	64	3	479	65	102	69	2	238	1794
% App. Total	9.4	80.3	9.4	0.9		26.6	50.8	21.9	0.7		7.5	78.5	13.4	0.6		27.3	42.9	29	0.8		
PHF	.652	.950	.830	.583	.911	.800	.832	.611	.500	.977	.750	.862	.762	.750	.868	.739	.797	.784	.250	.804	.944

