

ALLIANT ENGINEERING, INC.

733 S Marquette Ave #700, Minneapolis, MN 55402

MN 51 (Snelling Ave) & Midway Pkwy
 City: St. Paul
 data by: Spack Solutions
 TURN MOVEMENT COUNT

File Name : MN 51 (Snelling Ave) & Midway Pkwy_2021
 Site Code : 2405061
 Start Date : 10/19/2021
 Page No : 1

Groups Printed- Cars - Trucks

Start Time	MN 51 (Snelling Ave) Southbound					Midway Pkwy Westbound					MN 51 (Snelling Ave) Northbound					Dan Patch Ave Eastbound					Int. Total
	Left	Thru	Right	Peds	App. Total	Left	Thru	Right	Peds	App. Total	Left	Thru	Right	Peds	App. Total	Left	Thru	Right	Peds	App. Total	
06:00 AM	9	114	0	0	123	1	0	4	0	5	0	69	4	0	73	0	0	0	0	0	201
06:15 AM	15	159	0	0	174	1	0	3	0	4	0	94	3	0	97	0	0	0	0	0	275
06:30 AM	11	217	3	0	231	1	0	13	0	14	3	118	2	0	123	0	0	0	0	0	368
06:45 AM	11	268	10	1	290	1	2	2	0	5	6	128	7	0	141	0	0	0	0	0	436
Total	46	758	13	1	818	4	2	22	0	28	9	409	16	0	434	0	0	0	0	0	1280
07:00 AM	5	220	2	1	228	1	1	5	0	7	1	128	2	0	131	0	0	0	0	0	366
07:15 AM	3	311	3	0	317	2	1	6	0	9	4	208	4	0	216	0	1	0	0	1	543
07:30 AM	2	286	3	2	293	5	0	7	0	12	11	247	6	0	264	2	0	2	0	4	573
07:45 AM	11	326	2	0	339	1	0	5	0	6	7	249	3	1	260	0	0	1	0	1	606
Total	21	1143	10	3	1177	9	2	23	0	34	23	832	15	1	871	2	1	3	0	6	2088
08:00 AM	2	298	8	0	308	6	1	8	0	15	10	219	6	1	236	0	0	2	0	2	561
08:15 AM	8	300	10	1	319	2	0	7	0	9	5	205	7	0	217	1	1	0	0	2	547
08:30 AM	5	220	3	2	230	6	1	9	0	16	11	235	3	0	249	0	0	2	0	2	497
08:45 AM	8	296	6	4	314	4	0	6	0	10	3	209	4	0	216	0	0	3	0	3	543
Total	23	1114	27	7	1171	18	2	30	0	50	29	868	20	1	918	1	1	7	0	9	2148
09:00 AM	6	215	4	1	226	5	1	12	1	19	10	196	4	1	211	1	0	3	0	4	460
09:15 AM	8	255	1	1	265	6	1	7	0	14	3	175	5	0	183	2	0	1	0	3	465
09:30 AM	11	196	2	0	209	5	0	4	0	9	4	233	6	0	243	3	0	3	0	6	467
09:45 AM	25	235	3	2	265	6	1	5	0	12	3	204	13	2	222	1	2	2	0	5	504
Total	50	901	10	4	965	22	3	28	1	54	20	808	28	3	859	7	2	9	0	18	1896
10:00 AM	14	191	0	0	205	5	0	3	0	8	0	194	11	0	205	1	0	1	0	2	420
10:15 AM	22	172	1	4	199	6	1	2	1	10	2	208	9	0	219	1	1	0	0	2	430
10:30 AM	9	200	5	0	214	3	0	8	2	13	5	199	8	0	212	1	0	1	0	2	441
10:45 AM	6	185	5	0	196	3	0	5	1	9	1	230	9	0	240	0	0	5	0	5	450
Total	51	748	11	4	814	17	1	18	4	40	8	831	37	0	876	3	1	7	0	11	1741
11:00 AM	15	192	2	0	209	5	0	7	0	12	2	247	7	0	256	2	0	5	0	7	484
11:15 AM	12	238	2	0	252	4	3	8	1	16	2	297	13	0	312	6	1	1	0	8	588
11:30 AM	13	248	6	0	267	8	0	15	0	23	3	272	5	0	280	3	1	6	0	10	580
11:45 AM	12	231	2	2	247	6	0	15	1	22	1	282	8	1	292	5	1	4	0	10	571
Total	52	909	12	2	975	23	3	45	2	73	8	1098	33	1	1140	16	3	16	0	35	2223
12:00 PM	14	230	7	1	252	4	2	13	1	20	3	296	5	0	304	7	4	8	0	19	595
12:15 PM	11	269	6	1	287	9	3	13	1	26	4	271	7	0	282	8	2	1	0	11	606
12:30 PM	14	282	7	1	304	7	0	11	1	19	5	275	14	0	294	2	1	5	0	8	625
12:45 PM	14	276	6	1	297	9	0	11	0	20	5	242	6	0	253	4	2	6	0	12	582
Total	53	1057	26	4	1140	29	5	48	3	85	17	1084	32	0	1133	21	9	20	0	50	2408
01:00 PM	9	258	4	0	271	7	1	7	0	15	3	243	5	0	251	0	1	5	1	7	544
01:15 PM	13	270	0	0	283	13	0	9	0	22	6	271	12	0	289	0	0	6	0	6	600
01:30 PM	6	240	4	1	251	9	0	10	0	19	1	280	13	0	294	0	0	3	0	3	567
01:45 PM	15	245	2	1	263	9	1	5	0	15	1	287	7	1	296	3	0	2	0	5	579
Total	43	1013	10	2	1068	38	2	31	0	71	11	1081	37	1	1130	3	1	16	1	21	2290
02:00 PM	7	259	2	0	268	13	1	20	0	34	1	345	16	3	365	1	0	2	0	3	670
02:15 PM	8	254	1	0	263	19	0	9	0	28	2	320	5	1	328	1	0	2	0	3	622
02:30 PM	11	261	2	5	279	13	1	9	0	23	4	407	11	4	426	0	2	7	0	9	737
02:45 PM	16	271	3	1	291	6	1	14	0	21	2	289	11	0	302	1	1	5	0	7	621
Total	42	1045	8	6	1101	51	3	52	0	106	9	1361	43	8	1421	3	3	16	0	22	2650
03:00 PM	7	276	2	1	286	7	0	21	0	28	2	413	12	1	428	2	0	5	0	7	749

ALLIANT ENGINEERING, INC.

733 S Marquette Ave #700, Minneapolis, MN 55402

MN 51 (Snelling Ave) & Midway Pkwy
 City: St. Paul
 data by: Spack Solutions
 TURN MOVEMENT COUNT

File Name : MN 51 (Snelling Ave) & Midway Pkwy_2021
 Site Code : 2405061
 Start Date : 10/19/2021
 Page No : 2

Groups Printed- Cars - Trucks

Start Time	MN 51 (Snelling Ave) Southbound					Midway Pkwy Westbound					MN 51 (Snelling Ave) Northbound					Dan Patch Ave Eastbound					Int. Total
	Left	Thru	Right	Peds	App. Total	Left	Thru	Right	Peds	App. Total	Left	Thru	Right	Peds	App. Total	Left	Thru	Right	Peds	App. Total	
03:15 PM	5	275	1	0	281	13	0	10	1	24	2	408	8	3	421	11	0	2	0	13	739
03:30 PM	7	260	3	4	274	8	1	13	0	22	1	455	8	0	464	12	2	5	0	19	779
03:45 PM	6	247	1	0	254	4	0	14	1	19	0	383	10	0	393	0	1	3	0	4	670
Total	25	1058	7	5	1095	32	1	58	2	93	5	1659	38	4	1706	25	3	15	0	43	2937
04:00 PM	11	307	2	0	320	7	0	13	1	21	2	462	8	0	472	2	3	6	0	11	824
04:15 PM	9	267	2	0	278	9	0	9	0	18	1	417	10	0	428	7	1	4	0	12	736
04:30 PM	15	299	0	2	316	10	1	13	4	28	3	416	9	0	428	5	1	11	0	17	789
04:45 PM	11	346	1	0	358	4	0	10	0	14	2	461	13	0	476	2	2	4	0	8	856
Total	46	1219	5	2	1272	30	1	45	5	81	8	1756	40	0	1804	16	7	25	0	48	3205
05:00 PM	9	369	3	0	381	4	1	6	1	12	0	504	11	0	515	2	1	6	1	10	918
05:15 PM	1	287	1	2	291	7	0	3	1	11	1	388	12	1	402	5	1	10	0	16	720
05:30 PM	9	305	0	0	314	3	0	5	0	8	2	344	20	0	366	1	0	6	1	8	696
05:45 PM	7	287	0	1	295	4	3	11	0	18	2	299	12	0	313	4	0	2	0	6	632
Total	26	1248	4	3	1281	18	4	25	2	49	5	1535	55	1	1596	12	2	24	2	40	2966
06:00 PM	7	256	1	1	265	5	0	8	0	13	3	291	10	0	304	0	2	3	0	5	587
06:15 PM	6	241	2	1	250	1	0	6	0	7	2	296	9	1	308	3	0	1	0	4	569
06:30 PM	8	243	1	1	253	5	1	11	1	18	0	265	7	1	273	3	4	3	0	10	554
06:45 PM	1	240	0	1	242	7	1	5	0	13	0	212	10	0	222	2	1	3	0	6	483
Total	22	980	4	4	1010	18	2	30	1	51	5	1064	36	2	1107	8	7	10	0	25	2193
Grand Total	500	13193	147	47	13887	309	31	455	20	815	157	14386	430	22	14995	117	40	168	3	328	30025
Apprch %	3.6	95	1.1	0.3		37.9	3.8	55.8	2.5		1	95.9	2.9	0.1		35.7	12.2	51.2	0.9		
Total %	1.7	43.9	0.5	0.2	46.3	1	0.1	1.5	0.1	2.7	0.5	47.9	1.4	0.1	49.9	0.4	0.1	0.6	0	1.1	
Cars	496	12613	143	17	13269	304	31	453	12	800	157	13872	395	4	14428	113	40	165	3	321	28818
% Cars	99.2	95.6	97.3	36.2	95.5	98.4	100	99.6	60	98.2	100	96.4	91.9	18.2	96.2	96.6	100	98.2	100	97.9	96
Trucks	4	580	4	30	618	5	0	2	8	15	0	514	35	18	567	4	0	3	0	7	1207
% Trucks	0.8	4.4	2.7	63.8	4.5	1.6	0	0.4	40	1.8	0	3.6	8.1	81.8	3.8	3.4	0	1.8	0	2.1	4

ALLIANT ENGINEERING, INC.

733 S Marquette Ave #700, Minneapolis, MN 55402

MN 51 (Snelling Ave) & Midway Pkwy
 City: St. Paul
 data by: Spack Solutions
 TURN MOVEMENT COUNT

File Name : MN 51 (Snelling Ave) & Midway Pkwy_2021
 Site Code : 2405061
 Start Date : 10/19/2021
 Page No : 3

Start Time	MN 51 (Snelling Ave) Southbound					Midway Pkwy Westbound					MN 51 (Snelling Ave) Northbound					Dan Patch Ave Eastbound					Int. Total
	Left	Thru	Right	Peds	App. Total	Left	Thru	Right	Peds	App. Total	Left	Thru	Right	Peds	App. Total	Left	Thru	Right	Peds	App. Total	
Peak Hour Analysis From 06:00 AM to 09:45 AM - Peak 1 of 1																					
Peak Hour for Entire Intersection Begins at 07:30 AM																					
07:30 AM	2	286	3	2	293	5	0	7	0	12	11	247	6	0	264	2	0	2	0	4	573
07:45 AM	11	326	2	0	339	1	0	5	0	6	7	249	3	1	260	0	0	1	0	1	606
08:00 AM	2	298	8	0	308	6	1	8	0	15	10	219	6	1	236	0	0	2	0	2	561
08:15 AM	8	300	10	1	319	2	0	7	0	9	5	205	7	0	217	1	1	0	0	2	547
Total Volume	23	1210	23	3	1259	14	1	27	0	42	33	920	22	2	977	3	1	5	0	9	2287
% App. Total	1.8	96.1	1.8	0.2		33.3	2.4	64.3	0		3.4	94.2	2.3	0.2		33.3	11.1	55.6	0		
PHF	.523	.928	.575	.375	.928	.583	.250	.844	.000	.700	.750	.924	.786	.500	.925	.375	.250	.625	.000	.563	.943

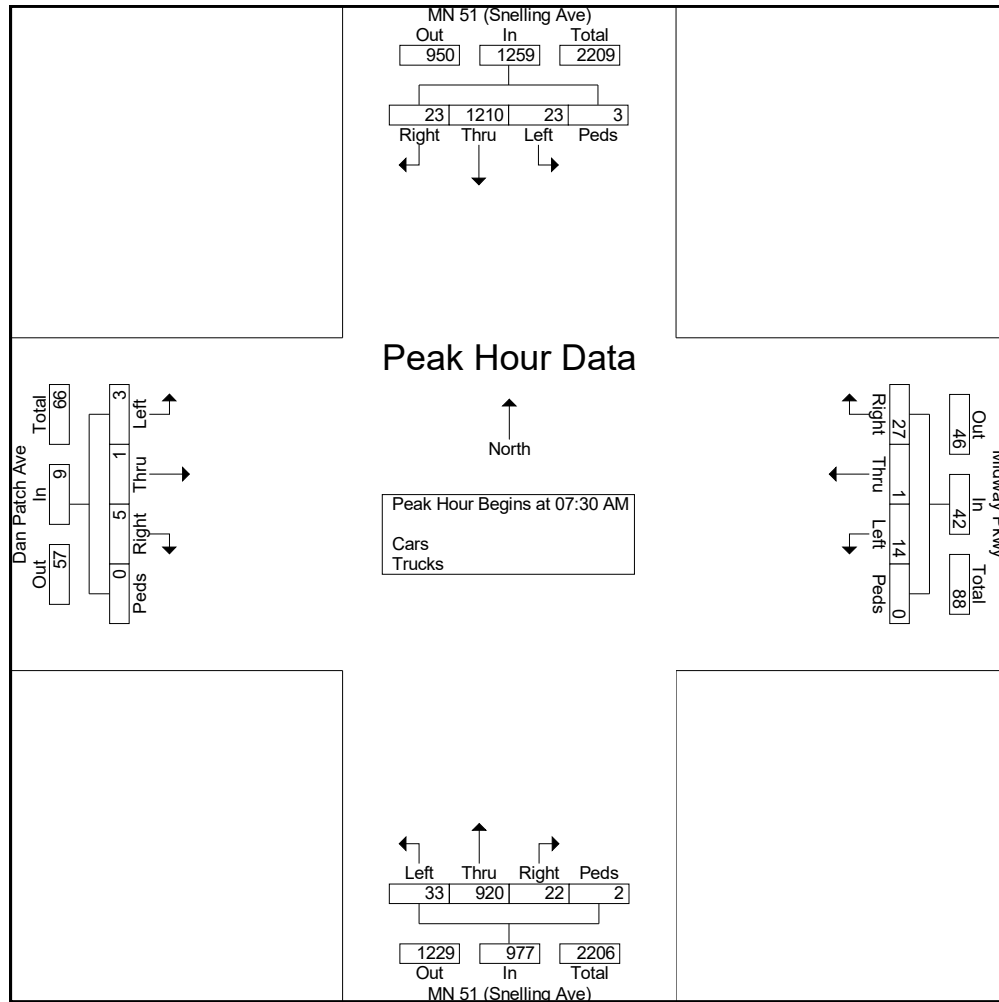

ALLIANT ENGINEERING, INC.

733 S Marquette Ave #700, Minneapolis, MN 55402

MN 51 (Snelling Ave) & Midway Pkwy
 City: St. Paul
 data by: Spack Solutions
 TURN MOVEMENT COUNT

File Name : MN 51 (Snelling Ave) & Midway Pkwy_2021
 Site Code : 2405061
 Start Date : 10/19/2021
 Page No : 4

Start Time	MN 51 (Snelling Ave) Southbound					Midway Pkwy Westbound					MN 51 (Snelling Ave) Northbound					Dan Patch Ave Eastbound					Int. Total
	Left	Thru	Right	Peds	App. Total	Left	Thru	Right	Peds	App. Total	Left	Thru	Right	Peds	App. Total	Left	Thru	Right	Peds	App. Total	
Peak Hour Analysis From 10:00 AM to 01:45 PM - Peak 1 of 1																					
Peak Hour for Entire Intersection Begins at 12:00 PM																					
12:00 PM	14	230	7	1	252	4	2	13	1	20	3	296	5	0	304	7	4	8	0	19	595
12:15 PM	11	269	6	1	287	9	3	13	1	26	4	271	7	0	282	8	2	1	0	11	606
12:30 PM	14	282	7	1	304	7	0	11	1	19	5	275	14	0	294	2	1	5	0	8	625
12:45 PM	14	276	6	1	297	9	0	11	0	20	5	242	6	0	253	4	2	6	0	12	582
Total Volume	53	1057	26	4	1140	29	5	48	3	85	17	1084	32	0	1133	21	9	20	0	50	2408
% App. Total	4.6	92.7	2.3	0.4		34.1	5.9	56.5	3.5		1.5	95.7	2.8	0		42	18	40	0		
PHF	.946	.937	.929	1.00	.938	.806	.417	.923	.750	.817	.850	.916	.571	.000	.932	.656	.563	.625	.000	.658	.963

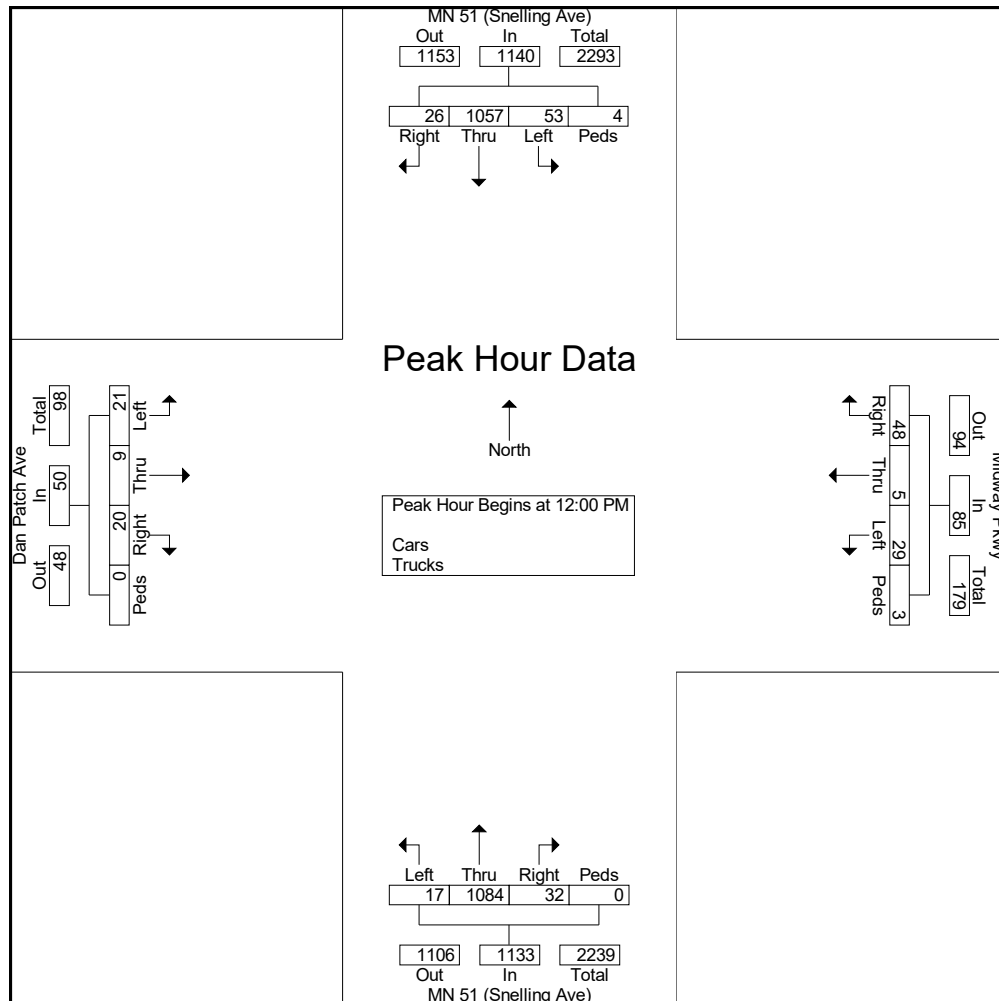

ALLIANT ENGINEERING, INC.

733 S Marquette Ave #700, Minneapolis, MN 55402

MN 51 (Snelling Ave) & Midway Pkwy
 City: St. Paul
 data by: Spack Solutions
 TURN MOVEMENT COUNT

File Name : MN 51 (Snelling Ave) & Midway Pkwy_2021
 Site Code : 2405061
 Start Date : 10/19/2021
 Page No : 5

Start Time	MN 51 (Snelling Ave) Southbound					Midway Pkwy Westbound					MN 51 (Snelling Ave) Northbound					Dan Patch Ave Eastbound					Int. Total
	Left	Thru	Right	Peds	App. Total	Left	Thru	Right	Peds	App. Total	Left	Thru	Right	Peds	App. Total	Left	Thru	Right	Peds	App. Total	
Peak Hour Analysis From 02:00 PM to 06:45 PM - Peak 1 of 1																					
Peak Hour for Entire Intersection Begins at 04:15 PM																					
04:15 PM	9	267	2	0	278	9	0	9	0	18	1	417	10	0	428	7	1	4	0	12	736
04:30 PM	15	299	0	2	316	10	1	13	4	28	3	416	9	0	428	5	1	11	0	17	789
04:45 PM	11	346	1	0	358	4	0	10	0	14	2	461	13	0	476	2	2	4	0	8	856
05:00 PM	9	369	3	0	381	4	1	6	1	12	0	504	11	0	515	2	1	6	1	10	918
Total Volume	44	1281	6	2	1333	27	2	38	5	72	6	1798	43	0	1847	16	5	25	1	47	3299
% App. Total	3.3	96.1	0.5	0.2		37.5	2.8	52.8	6.9		0.3	97.3	2.3	0		34	10.6	53.2	2.1		
PHF	.733	.868	.500	.250	.875	.675	.500	.731	.313	.643	.500	.892	.827	.000	.897	.571	.625	.568	.250	.691	.898

