



MINNESOTA DEPT OF TRANSPORTATION

TRAFFIC DATA COLLECTION - METRO

LAFAYETTE RD W AT EATON ST.
 REF.PT.:
 JAMAR # 632 DR
 TURN MOVEMENT COUNT

File Name : LAFAYETTE RD W AT EATON ST 2006
 Site Code : 00000000
 Start Date : 8/2/2006
 Page No : 1

Groups Printed- Cars & Trucks

Start Time	W LAFAYETTE RD Southbound				EATON ST Westbound				EATON ST Eastbound				Int. Total
	Left	Thru	Right	Peds	Left	Thru	Right	Peds	Left	Thru	Right	Peds	
06:00	16	0	2	0	0	1	0	0	0	2	0	0	21
06:15	15	0	1	0	0	4	0	0	0	4	0	0	24
06:30	11	0	3	0	0	3	0	0	0	5	0	0	22
06:45	12	0	3	0	0	3	0	0	0	4	0	0	22
Total	54	0	9	0	0	11	0	0	0	15	0	0	89
07:00	14	0	1	0	0	1	0	0	0	6	0	0	22
07:15	18	0	0	0	0	6	0	0	0	5	0	0	29
07:30	13	0	1	0	0	4	0	0	0	4	0	0	22
07:45	21	0	1	0	0	3	0	0	0	3	0	0	28
Total	66	0	3	0	0	14	0	0	0	18	0	0	101
08:00	11	0	1	0	0	2	0	0	0	5	0	0	19
08:15	22	0	2	0	0	2	0	0	0	7	0	0	33
08:30	13	0	1	0	0	5	0	0	0	7	0	0	26
08:45	9	0	4	0	0	1	0	0	0	5	0	0	19
Total	55	0	8	0	0	10	0	0	0	24	0	0	97
*** BREAK ***													
15:00	20	0	4	0	0	8	0	0	0	10	0	0	42
15:15	8	0	2	0	0	6	0	0	0	8	0	0	24
15:30	8	0	1	0	0	9	0	0	0	14	0	0	32
15:45	8	0	0	0	0	4	0	0	0	4	0	0	16
Total	44	0	7	0	0	27	0	0	0	36	0	0	114
16:00	11	0	2	0	0	13	0	0	0	17	0	0	43
16:15	9	0	2	0	0	7	0	0	0	5	0	0	23
16:30	13	0	4	0	0	12	0	0	0	26	0	0	55
16:45	8	0	2	0	0	5	0	0	0	9	0	0	24
Total	41	0	10	0	0	37	0	0	0	57	0	0	145
17:00	16	0	2	0	0	5	0	0	0	7	0	0	30
17:15	6	0	0	0	0	10	0	0	0	3	0	0	19
17:30	6	0	2	0	0	8	0	0	0	5	0	0	21
17:45	8	0	1	0	0	3	0	0	0	0	0	0	12
Total	36	0	5	0	0	26	0	0	0	15	0	0	82
Grand Total	296	0	42	0	0	125	0	0	0	165	0	0	628
Apprch %	87.6	0	12.4	0	0	100	0	0	0	100	0	0	
Total %	47.1	0	6.7	0	0	19.9	0	0	0	26.3	0	0	



MINNESOTA DEPT OF TRANSPORTATION

TRAFFIC DATA COLLECTION - METRO

LAFAYETTE RD W AT EATON ST.
 REF.PT.:
 JAMAR # 632 DR
 TURN MOVEMENT COUNT

File Name : LAFAYETTE RD W AT EATON ST 2006
 Site Code : 00000000
 Start Date : 8/2/2006
 Page No : 2

Start Time	W LAFAYETTE RD Southbound					EATON ST Westbound					EATON ST Eastbound					Int. Total
	Left	Thru	Right	Peds	App. Total	Left	Thru	Right	Peds	App. Total	Left	Thru	Right	Peds	App. Total	
Peak Hour Analysis From 06:00 to 08:45 - Peak 1 of 1																
Peak Hour for Entire Intersection Begins at 07:45																
07:45	21	0	1	0	22	0	3	0	0	3	0	3	0	0	3	28
08:00	11	0	1	0	12	0	2	0	0	2	0	5	0	0	5	19
08:15	22	0	2	0	24	0	2	0	0	2	0	7	0	0	7	33
08:30	13	0	1	0	14	0	5	0	0	5	0	7	0	0	7	26
Total Volume	67	0	5	0	72	0	12	0	0	12	0	22	0	0	22	106
% App. Total	93.1	0	6.9	0		0	100	0	0		0	100	0	0		
PHF	.761	.000	.625	.000	.750	.000	.600	.000	.000	.600	.000	.786	.000	.000	.786	.803

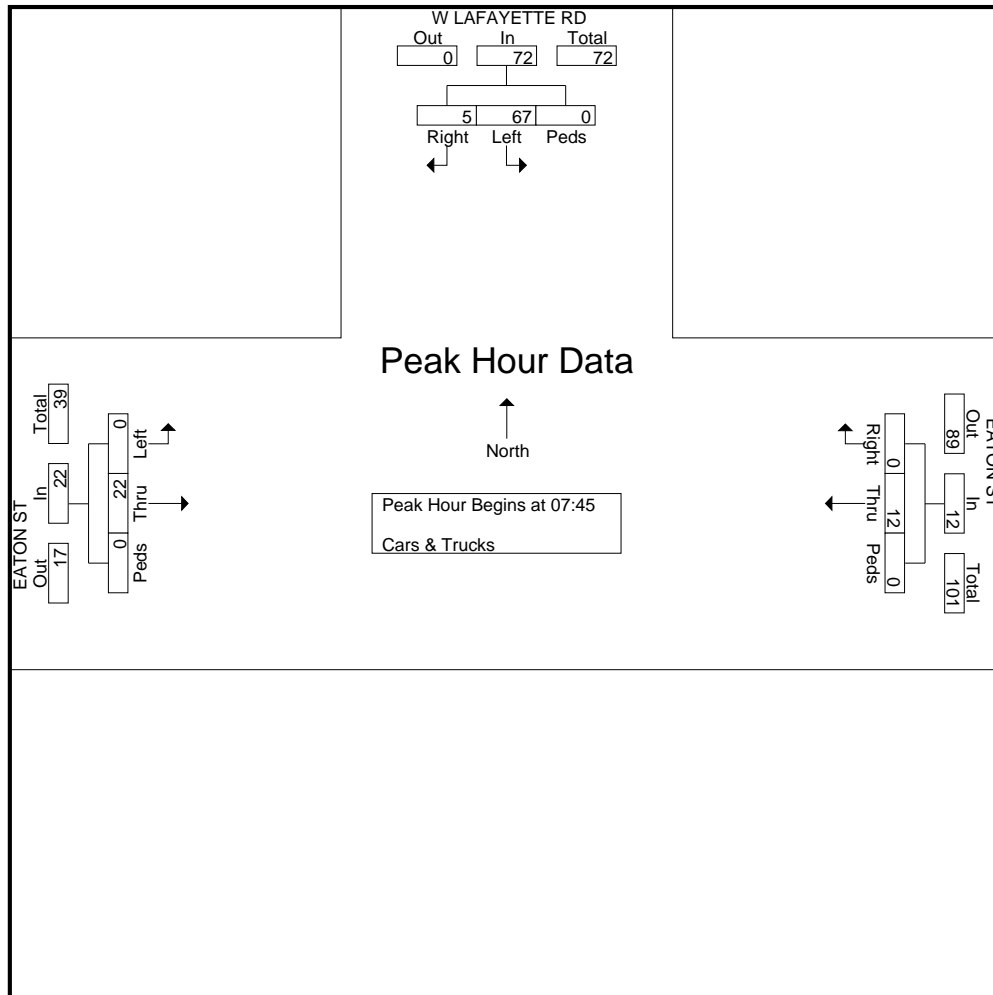



MINNESOTA DEPT OF TRANSPORTATION

TRAFFIC DATA COLLECTION - METRO

LAFAYETTE RD W AT EATON ST.
 REF.PT.:
 JAMAR # 632 DR
 TURN MOVEMENT COUNT

File Name : LAFAYETTE RD W AT EATON ST 2006
 Site Code : 00000000
 Start Date : 8/2/2006
 Page No : 3

Start Time	W LAFAYETTE RD Southbound					EATON ST Westbound					EATON ST Eastbound					Int. Total
	Left	Thru	Right	Peds	App. Total	Left	Thru	Right	Peds	App. Total	Left	Thru	Right	Peds	App. Total	
Peak Hour Analysis From 15:00 to 17:45 - Peak 1 of 1																
Peak Hour for Entire Intersection Begins at 16:00																
16:00	11	0	2	0	13	0	13	0	0	13	0	17	0	0	17	43
16:15	9	0	2	0	11	0	7	0	0	7	0	5	0	0	5	23
16:30	13	0	4	0	17	0	12	0	0	12	0	26	0	0	26	55
16:45	8	0	2	0	10	0	5	0	0	5	0	9	0	0	9	24
Total Volume	41	0	10	0	51	0	37	0	0	37	0	57	0	0	57	145
% App. Total	80.4	0	19.6	0		0	100	0	0		0	100	0	0		
PHF	.788	.000	.625	.000	.750	.000	.712	.000	.000	.712	.000	.548	.000	.000	.548	.659

