



Arrowhead

Out	In	Total
164	105	269
0	0	0
0	0	0
164	105	269

19	22	64	0
0	0	0	0
0	0	0	0
19	22	64	0

Right   Thru   Left   Peds

←   ↓   →

TH 55

Out	In	Total
5592	5507	11099
0	0	0
0	0	0
5592	5507	11099

0	127	5314	66
0	0	0	0
0	0	0	0
0	127	5314	66

Peds   Right   Thru   Left

↓   →   ←

North

7/25/2006 06:00  
 7/25/2006 17:45  
 Unshifted  
 Bank 1  
 Bank 2

TH 55

Out	In	Total
5994	6190	12184
0	0	0
5994	6190	12184

68	5436	685	1
0	0	0	0
0	0	0	0
68	5436	685	1

Right   Thru   Left   Peds

←   ↓   →

Left	Thru	Right	Peds
137	30	616	0
0	0	0	0
0	0	0	0
137	30	616	0

834	783	1617
0	0	0
0	0	0
834	783	1617

Out   In   Total

Arrowhead



# MINNESOTA DEPT OF TRANSPORTATION

## TRAFFIC DATA COLLECTION - METRO

File Name : TH 55 @ ARROWHEAD DRIVE 2006  
 Site Code : 07250112  
 Start Date : 7/25/2006  
 Page No : 3

Start Time	Arrowhead Southbound					TH 55 Westbound					Arrowhead Northbound					TH 55 Eastbound					Int. Total
	Left	Thru	Right	Peds	App. Total	Left	Thru	Right	Peds	App. Total	Left	Thru	Right	Peds	App. Total	Left	Thru	Right	Peds	App. Total	
Peak Hour Analysis From 06:00 to 09:45 - Peak 1 of 1																					
Peak Hour for Entire Intersection Begins at 06:45																					
06:45	0	1	0	0	1	56	86	8	0	150	0	1	8	0	9	7	270	13	0	290	450
07:00	4	0	0	0	4	32	101	3	1	137	3	0	11	0	14	0	294	3	0	297	452
07:15	0	0	1	0	1	30	104	2	0	136	5	0	20	0	25	1	265	7	0	273	435
07:30	2	2	0	0	4	18	123	3	0	144	2	0	13	0	15	1	308	10	0	319	482
Total Volume	6	3	1	0	10	136	414	16	1	567	10	1	52	0	63	9	1137	33	0	1179	1819
% App. Total	60	30	10	0		24	73	2.8	0.2		15.9	1.6	82.5	0		0.8	96.4	2.8	0		
PHF	.375	.375	.250	.000	.625	.607	.841	.500	.250	.945	.500	.250	.650	.000	.630	.321	.923	.635	.000	.924	.943

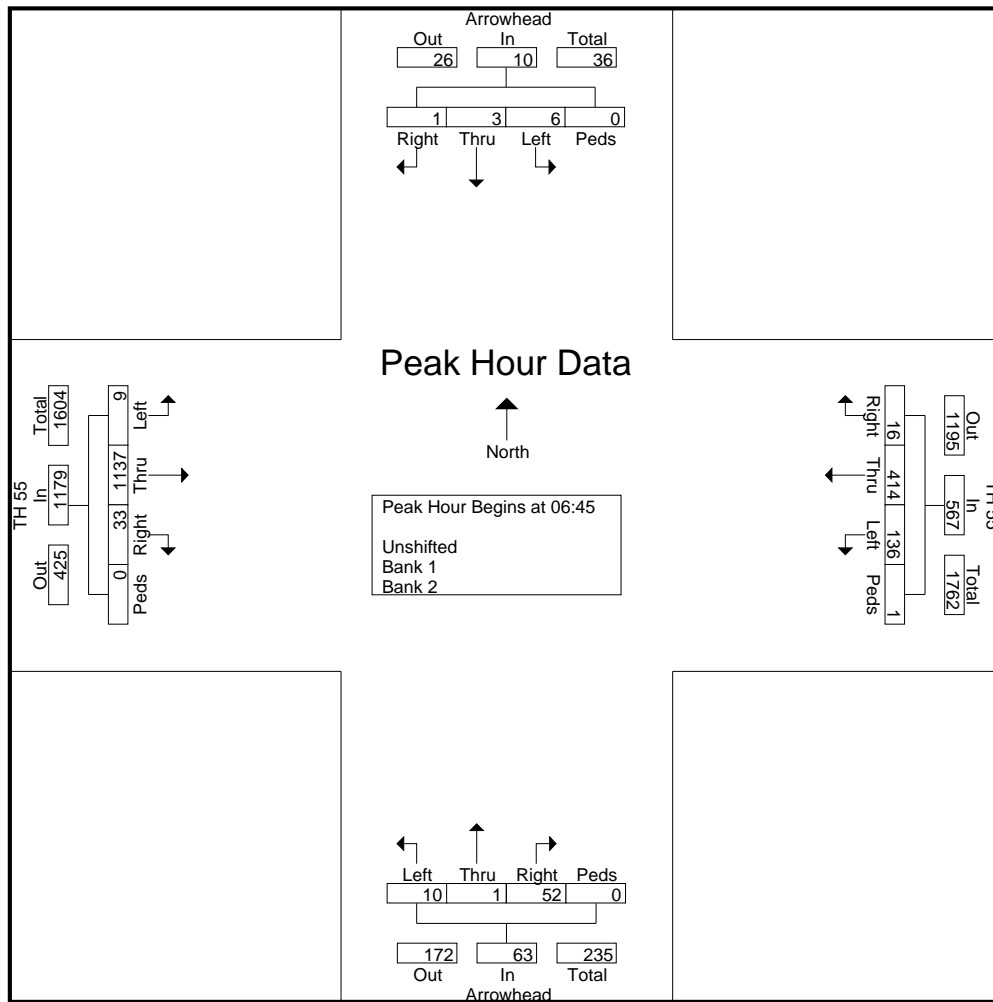



# MINNESOTA DEPT OF TRANSPORTATION

## TRAFFIC DATA COLLECTION - METRO

File Name : TH 55 @ ARROWHEAD DRIVE 2006  
 Site Code : 07250112  
 Start Date : 7/25/2006  
 Page No : 4

Start Time	Arrowhead Southbound					TH 55 Westbound					Arrowhead Northbound					TH 55 Eastbound					Int. Total
	Left	Thru	Right	Peds	App. Total	Left	Thru	Right	Peds	App. Total	Left	Thru	Right	Peds	App. Total	Left	Thru	Right	Peds	App. Total	
11:45	3	1	0	0	4	12	97	4	0	113	1	1	21	0	23	0	106	4	0	110	250
12:00	5	0	0	0	5	23	102	2	0	127	4	0	24	0	28	1	126	3	0	130	290
12:15	0	1	0	0	1	13	109	6	0	128	3	2	18	0	23	3	126	1	0	130	282
12:30	5	0	0	0	5	32	130	2	0	164	3	2	11	0	16	5	128	3	0	136	321
Total Volume	13	2	0	0	15	80	438	14	0	532	11	5	74	0	90	9	486	11	0	506	1143
% App. Total	86.7	13.3	0	0		15	82.3	2.6	0		12.2	5.6	82.2	0		1.8	96	2.2	0		
PHF	.650	.500	.000	.000	.750	.625	.842	.583	.000	.811	.688	.625	.771	.000	.804	.450	.949	.688	.000	.930	.890

Peak Hour Analysis From 10:00 to 13:45 - Peak 1 of 1  
 Peak Hour for Entire Intersection Begins at 11:45

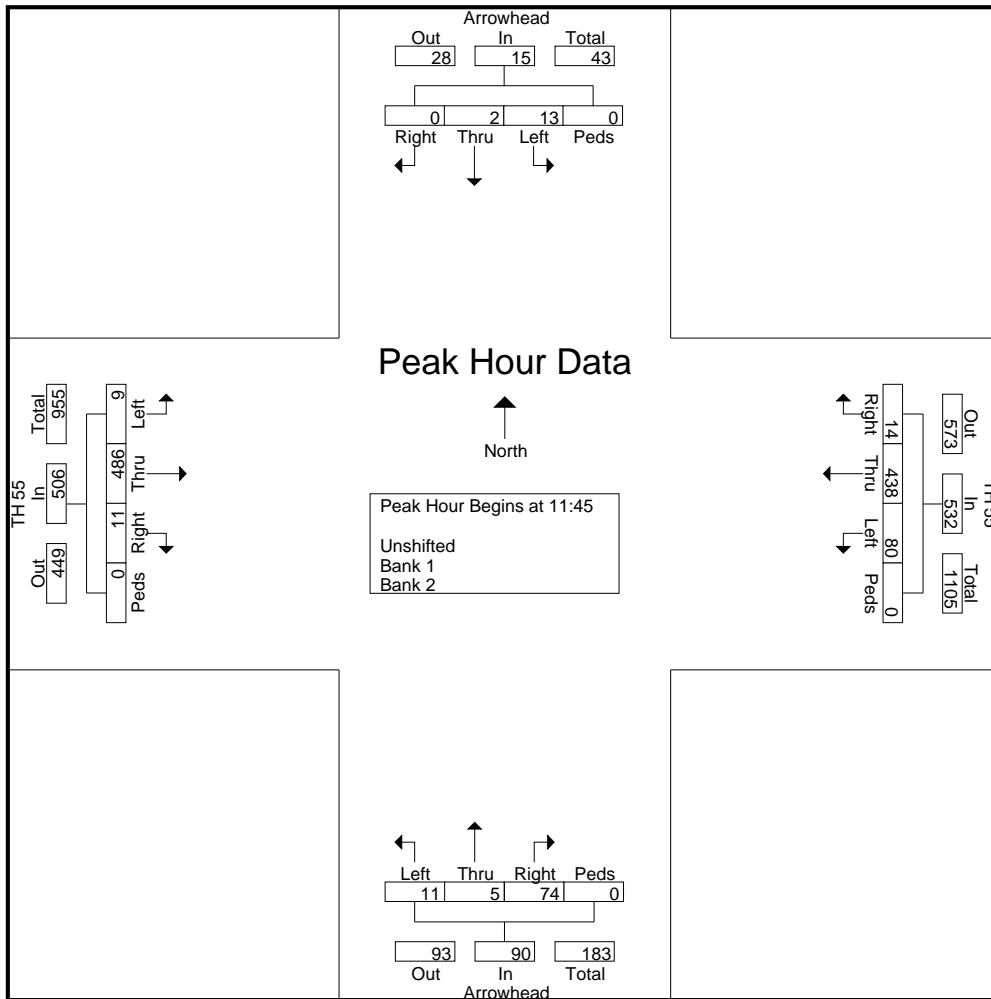



# MINNESOTA DEPT OF TRANSPORTATION

## TRAFFIC DATA COLLECTION - METRO

File Name : TH 55 @ ARROWHEAD DRIVE 2006  
 Site Code : 07250112  
 Start Date : 7/25/2006  
 Page No : 5

Start Time	Arrowhead Southbound					TH 55 Westbound					Arrowhead Northbound					TH 55 Eastbound					Int. Total
	Left	Thru	Right	Peds	App. Total	Left	Thru	Right	Peds	App. Total	Left	Thru	Right	Peds	App. Total	Left	Thru	Right	Peds	App. Total	
16:30	4	0	0	0	4	18	281	1	0	300	16	2	61	0	79	0	122	2	0	124	507
16:45	3	3	2	0	8	16	299	1	0	316	6	1	18	0	25	0	118	2	0	120	469
17:00	1	1	0	0	2	12	331	2	0	345	7	1	33	0	41	2	125	1	0	128	516
17:15	2	0	2	0	4	19	322	1	0	342	13	3	25	0	41	1	139	0	0	140	527
Total Volume	10	4	4	0	18	65	1233	5	0	1303	42	7	137	0	186	3	504	5	0	512	2019
% App. Total	55.6	22.2	22.2	0		5	94.6	0.4	0		22.6	3.8	73.7	0		0.6	98.4	1	0		
PHF	.625	.333	.500	.000	.563	.855	.931	.625	.000	.944	.656	.583	.561	.000	.589	.375	.906	.625	.000	.914	.958

Peak Hour Analysis From 14:00 to 17:45 - Peak 1 of 1  
 Peak Hour for Entire Intersection Begins at 16:30

