



MINNESOTA DEPT OF TRANSPORTATION

TRAFFIC DATA COLLECTION - METRO

TH-61 at White Bear Ave / Hoffman Rd.

Ref.Pt.: 146.268

Data by: Alliant Inc.

TURN MOVEMENT COUNT

File Name : TH-61 at White Bear Ave WBL 2008

Site Code : 00000113

Start Date : 9/9/2008

Page No : 1

Groups Printed- Unshifted

Start Time	TH-61 Southbound				White Bear Ave Westbound				TH-61 Northbound				Hoffman Rd. Eastbound				Int. Total	
	Left	Thru	Right	Peds	Left	Thru	Right	Peds	Left	Thru	Right	Peds	Left	Thru	Right	Peds		
06:00	18	116	3	0	0	1	25	0	0	32	1	0	0	0	0	0	0	196
06:15	28	188	4	0	4	2	29	0	0	35	1	0	1	0	0	0	0	292
06:30	29	237	4	0	6	0	43	0	0	58	2	0	0	0	0	0	0	379
06:45	50	265	2	0	7	8	66	0	0	61	3	0	1	1	0	0	0	464
Total	125	806	13	0	17	11	163	0	0	186	7	0	2	1	0	0	0	1331
07:00	84	368	4	0	6	1	65	0	1	72	0	0	3	1	0	0	0	605
07:15	98	381	4	0	9	4	92	0	0	69	4	0	3	4	0	0	0	668
07:30	50	328	5	0	8	2	63	0	0	63	5	0	1	1	0	0	0	526
07:45	69	305	8	0	7	2	90	0	0	98	5	0	1	3	0	0	0	588
Total	301	1382	21	0	30	9	310	0	1	302	14	0	8	9	0	0	0	2387
08:00	40	175	8	0	6	4	55	0	1	75	0	0	3	0	1	0	0	368
08:15	39	178	6	0	7	2	41	0	0	86	2	0	7	1	2	0	0	371
08:30	40	175	9	0	11	1	54	0	2	97	2	0	5	4	0	0	0	400
08:45	58	185	5	0	12	0	58	0	0	94	6	0	8	1	1	0	0	428
Total	177	713	28	0	36	7	208	0	3	352	10	0	23	6	4	0	0	1567
09:00	42	156	3	0	8	2	68	1	0	97	6	0	6	0	0	0	0	389
09:15	45	142	5	0	10	3	76	0	1	67	2	0	6	0	0	0	0	357
*** BREAK ***																		
Total	87	298	8	0	18	5	144	1	1	164	8	0	12	0	0	0	0	746
*** BREAK ***																		
10:30	47	129	3	0	16	0	58	0	0	106	7	1	2	1	2	0	0	372
10:45	43	127	2	0	8	1	77	0	1	101	9	0	3	0	0	0	0	372
Total	90	256	5	0	24	1	135	0	1	207	16	1	5	1	2	0	0	744
11:00	34	116	5	0	11	5	66	0	0	118	5	0	2	0	0	0	0	362
11:15	46	135	4	0	11	0	82	0	0	123	2	0	6	2	1	0	0	412
11:30	56	125	4	0	15	4	70	0	2	118	9	0	8	2	0	0	0	413
11:45	47	134	3	0	11	6	71	0	0	134	5	0	7	3	2	0	0	423
Total	183	510	16	0	48	15	289	0	2	493	21	0	23	7	3	0	0	1610
12:00	49	146	3	0	16	2	80	0	0	159	9	0	8	1	1	0	0	474
12:15	46	152	3	0	12	3	69	1	0	148	5	0	3	3	0	0	0	445
12:30	59	167	10	0	16	4	86	0	1	145	4	0	8	1	2	0	0	503
12:45	52	150	7	0	11	8	81	0	1	129	6	0	16	0	0	0	0	461
Total	206	615	23	0	55	17	316	1	2	581	24	0	35	5	3	0	0	1883
13:00	57	112	4	0	9	3	94	2	1	136	6	0	11	0	1	0	0	436
13:15	42	127	6	0	11	4	81	0	1	144	10	0	3	2	0	0	0	431
*** BREAK ***																		
Total	99	239	10	0	20	7	175	2	2	280	16	0	14	2	1	0	0	867
*** BREAK ***																		
14:30	64	160	5	0	11	3	112	0	1	183	8	0	1	1	0	0	0	549
14:45	63	139	1	0	9	3	138	0	0	222	17	0	8	4	3	0	0	607
Total	127	299	6	0	20	6	250	0	1	405	25	0	9	5	3	0	0	1156
15:00	66	145	3	0	12	2	98	0	3	277	12	0	9	1	2	0	0	630
15:15	63	139	9	0	4	5	104	0	2	311	8	0	5	2	1	1	1	654
15:30	65	169	5	0	17	5	112	0	2	273	4	1	6	2	0	1	1	662
15:45	80	150	4	0	12	7	122	0	1	247	9	0	5	5	0	0	0	642
Total	274	603	21	0	45	19	436	0	8	1108	33	1	25	10	3	2	2	2588



MINNESOTA DEPT OF TRANSPORTATION

TRAFFIC DATA COLLECTION - METRO

TH-61 at White Bear Ave / Hoffman Rd.

Ref.Pt.: 146.268

Data by: Alliant Inc.

TURN MOVEMENT COUNT

File Name : TH-61 at White Bear Ave WBL 2008

Site Code : 00000113

Start Date : 9/9/2008

Page No : 2

Groups Printed- Unshifted

Start Time	TH-61 Southbound				White Bear Ave Westbound				TH-61 Northbound				Hoffman Rd. Eastbound				Int. Total
	Left	Thru	Right	Peds	Left	Thru	Right	Peds	Left	Thru	Right	Peds	Left	Thru	Right	Peds	
16:00	87	175	5	0	10	2	100	0	0	242	9	0	7	3	1	0	641
16:15	82	173	6	0	16	8	99	0	0	247	10	0	4	2	1	0	648
16:30	111	203	14	0	6	3	118	0	3	276	8	0	10	4	0	0	756
16:45	87	162	1	0	11	5	106	0	1	270	12	0	7	3	0	0	665
Total	367	713	26	0	43	18	423	0	4	1035	39	0	28	12	2	0	2710
17:00	116	202	4	0	10	2	123	0	2	343	19	0	5	4	0	0	830
17:15	97	177	6	0	10	6	110	0	0	309	13	0	10	0	0	0	738
17:30	65	153	4	0	13	9	124	0	2	292	9	0	2	0	0	0	673
17:45	79	146	2	1	6	5	107	0	1	251	14	0	2	3	2	1	620
Total	357	678	16	1	39	22	464	0	5	1195	55	0	19	7	2	1	2861
Grand Total	2393	7112	193	1	395	137	3313	4	30	6308	268	2	203	65	23	3	20450
Apprch %	24.7	73.3	2	0	10.3	3.6	86.1	0.1	0.5	95.5	4.1	0	69	22.1	7.8	1	
Total %	11.7	34.8	0.9	0	1.9	0.7	16.2	0	0.1	30.8	1.3	0	1	0.3	0.1	0	



MINNESOTA DEPT OF TRANSPORTATION

TRAFFIC DATA COLLECTION - METRO

TH-61 at White Bear Ave / Hoffman Rd.
 Ref.Pt.: 146.268
 Data by: Alliant Inc.
 TURN MOVEMENT COUNT

File Name : TH-61 at White Bear Ave WBL 2008
 Site Code : 00000113
 Start Date : 9/9/2008
 Page No : 3

Start Time	TH-61 Southbound					White Bear Ave Westbound					TH-61 Northbound					Hoffman Rd. Eastbound					Int. Total
	Left	Thru	Right	Peds	App. Total	Left	Thru	Right	Peds	App. Total	Left	Thru	Right	Peds	App. Total	Left	Thru	Right	Peds	App. Total	
Peak Hour Analysis From 06:00 to 09:15 - Peak 1 of 1																					
Peak Hour for Entire Intersection Begins at 07:00																					
07:00	84	368	4	0	456	6	1	65	0	72	1	72	0	0	73	3	1	0	0	4	605
07:15	98	381	4	0	483	9	4	92	0	105	0	69	4	0	73	3	4	0	0	7	668
07:30	50	328	5	0	383	8	2	63	0	73	0	63	5	0	68	1	1	0	0	2	526
07:45	69	305	8	0	382	7	2	90	0	99	0	98	5	0	103	1	3	0	0	4	588
Total Volume	301	1382	21	0	1704	30	9	310	0	349	1	302	14	0	317	8	9	0	0	17	2387
% App. Total	17.7	81.1	1.2	0		8.6	2.6	88.8	0		0.3	95.3	4.4	0		47.1	52.9	0	0		
PHF	.768	.907	.656	.000	.882	.833	.563	.842	.000	.831	.250	.770	.700	.000	.769	.667	.563	.000	.000	.607	.893

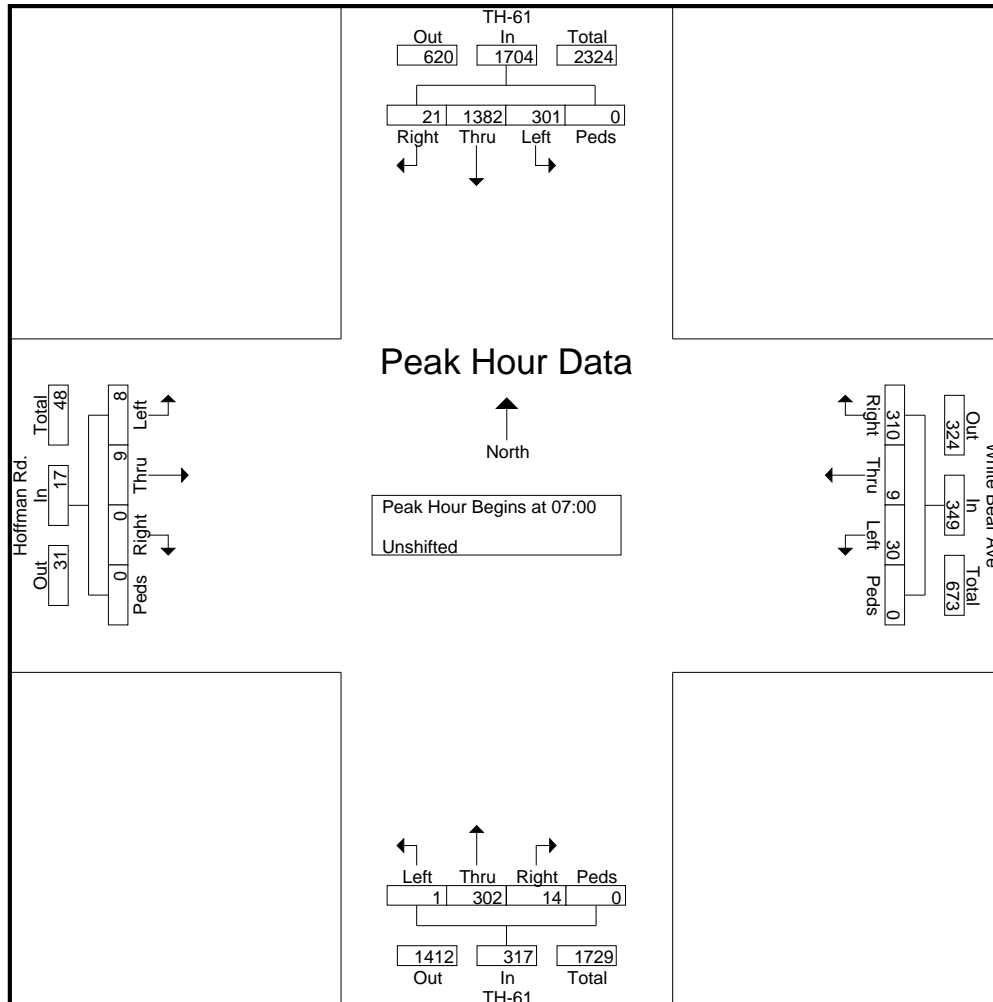



MINNESOTA DEPT OF TRANSPORTATION

TRAFFIC DATA COLLECTION - METRO

TH-61 at White Bear Ave / Hoffman Rd.

Ref.Pt.: 146.268

Data by: Alliant Inc.

TURN MOVEMENT COUNT

File Name : TH-61 at White Bear Ave WBL 2008

Site Code : 00000113

Start Date : 9/9/2008

Page No : 4

Start Time	TH-61 Southbound					White Bear Ave Westbound					TH-61 Northbound					Hoffman Rd. Eastbound					Int. Total
	Left	Thru	Right	Peds	App. Total	Left	Thru	Right	Peds	App. Total	Left	Thru	Right	Peds	App. Total	Left	Thru	Right	Peds	App. Total	

Peak Hour Analysis From 14:30 to 17:45 - Peak 1 of 1

Peak Hour for Entire Intersection Begins at 16:30

16:30	111	203	14	0	328	6	3	118	0	127	3	276	8	0	287	10	4	0	0	14	756
16:45	87	162	1	0	250	11	5	106	0	122	1	270	12	0	283	7	3	0	0	10	665
17:00	116	202	4	0	322	10	2	123	0	135	2	343	19	0	364	5	4	0	0	9	830
17:15	97	177	6	0	280	10	6	110	0	126	0	309	13	0	322	10	0	0	0	10	738
Total Volume	411	744	25	0	1180	37	16	457	0	510	6	1198	52	0	1256	32	11	0	0	43	2989
% App. Total	34.8	63.1	2.1	0		7.3	3.1	89.6	0		0.5	95.4	4.1	0		74.4	25.6	0	0		
PHF	.886	.916	.446	.000	.899	.841	.667	.929	.000	.944	.500	.873	.684	.000	.863	.800	.688	.000	.000	.768	.900

