

Alliant Engineering Inc Minneapolis, MN 55415

TH-65 at 93rd Ave NE / Clover Leaf Pkwy
 Ref.Pt.: 011.484
 data by Alliant Engineering Inc
 TURN MOVEMENT COUNT

File Name : TH-65 at 93rd Ave NE 2009
 Site Code : 00000013
 Start Date : 1/13/2009
 Page No : 1

Groups Printed- Unshifted

Start Time	TH-65 Southbound				93rd Ave NE Westbound				TH-65 Northbound				Clover Leaf Pkwy NE Eastbound				Int. Total
	Left	Thru	Right	Peds	Left	Thru	Right	Peds	Left	Thru	Right	Peds	Left	Thru	Right	Peds	
06:00	6	427	1	0	27	1	2	0	2	65	25	0	1	14	48	0	619
06:15	11	452	0	0	61	2	3	0	1	94	14	0	1	22	53	0	714
06:30	4	445	2	0	61	2	6	0	4	99	24	0	0	16	53	0	716
06:45	9	424	1	0	112	1	8	0	3	128	44	0	4	38	49	0	821
Total	30	1748	4	0	261	6	19	0	10	386	107	0	6	90	203	0	2870
07:00	6	437	0	0	99	1	9	0	11	109	39	0	0	28	53	0	792
07:15	5	407	1	0	94	3	4	0	16	151	32	0	0	26	54	2	795
07:30	6	442	1	0	102	2	13	0	9	179	36	0	3	25	62	0	880
07:45	9	416	1	0	88	2	12	0	8	175	29	0	3	30	41	0	814
Total	26	1702	3	0	383	8	38	0	44	614	136	0	6	109	210	2	3281
08:00	8	402	2	0	85	2	8	0	8	122	31	0	2	18	29	0	717
08:15	12	426	2	0	94	9	12	0	14	149	20	0	5	16	37	0	796
08:30	12	400	2	0	76	3	19	0	14	131	19	1	2	13	27	0	719
08:45	10	353	5	0	89	5	31	0	15	167	32	0	4	8	34	0	753
Total	42	1581	11	0	344	19	70	0	51	569	102	1	13	55	127	0	2985
09:00	10	384	7	0	85	8	18	0	12	162	30	0	6	10	18	0	750
09:15	12	379	9	0	56	8	21	0	16	154	33	0	3	15	20	0	726
*** BREAK ***																	
Total	22	763	16	0	141	16	39	0	28	316	63	0	9	25	38	0	1476
*** BREAK ***																	
10:30	10	219	2	0	35	8	26	0	11	164	38	0	6	7	13	0	539
10:45	13	232	6	0	43	9	16	0	9	195	40	0	8	13	19	0	603
Total	23	451	8	0	78	17	42	0	20	359	78	0	14	20	32	0	1142
11:00	14	201	5	0	60	4	15	1	9	190	27	0	8	9	19	0	562
11:15	16	236	7	0	38	10	17	0	11	234	34	0	10	16	18	0	647
11:30	16	234	8	0	56	9	29	0	11	178	46	0	7	13	17	0	624
11:45	13	223	5	0	51	10	18	0	11	241	37	0	7	13	19	0	648
Total	59	894	25	0	205	33	79	1	42	843	144	0	32	51	73	0	2481
12:00	27	203	6	0	82	8	34	0	13	216	48	0	8	19	16	0	680
12:15	22	272	3	0	51	15	25	0	21	280	41	0	9	16	27	0	782
12:30	24	269	5	0	50	17	18	0	9	232	41	0	8	21	20	0	714
12:45	17	262	7	0	48	10	24	0	11	254	44	0	10	25	15	0	727
Total	90	1006	21	0	231	50	101	0	54	982	174	0	35	81	78	0	2903
13:00	18	249	11	0	47	9	21	0	10	190	54	0	6	19	19	0	653
13:15	9	279	11	0	49	4	17	0	16	255	50	0	8	20	22	0	740
*** BREAK ***																	
Total	27	528	22	0	96	13	38	0	26	445	104	0	14	39	41	0	1393
*** BREAK ***																	
14:30	16	239	15	0	50	7	26	0	21	400	35	0	9	12	24	0	854
14:45	23	245	11	0	50	22	28	0	50	466	60	0	15	14	19	0	1003
Total	39	484	26	0	100	29	54	0	71	866	95	0	24	26	43	0	1857
15:00	19	282	8	0	50	27	39	0	39	431	54	0	11	19	16	0	995
15:15	17	256	10	0	52	21	28	0	37	466	75	0	6	17	21	0	1006
15:30	14	243	5	0	66	16	46	0	27	493	85	0	6	17	21	0	1039
15:45	9	257	7	0	39	25	33	0	34	495	104	0	5	11	16	0	1035
Total	59	1038	30	0	207	89	146	0	137	1885	318	0	28	64	74	0	4075

Alliant Engineering Inc Minneapolis, MN 55415

TH-65 at 93rd Ave NE / Clover Leaf Pkwy
 Ref.Pt.: 011.484
 data by Alliant Engineering Inc
 TURN MOVEMENT COUNT

File Name : TH-65 at 93rd Ave NE 2009
 Site Code : 00000013
 Start Date : 1/13/2009
 Page No : 2

Groups Printed- Unshifted

Start Time	TH-65 Southbound				93rd Ave NE Westbound				TH-65 Northbound				Clover Leaf Pkwy NE Eastbound				Int. Total
	Left	Thru	Right	Peds	Left	Thru	Right	Peds	Left	Thru	Right	Peds	Left	Thru	Right	Peds	
16:00	19	241	7	0	58	29	32	0	29	523	79	0	10	18	18	0	1063
16:15	15	246	10	0	56	32	37	0	46	517	113	0	8	21	26	0	1127
16:30	18	303	8	0	58	38	41	3	39	509	149	0	13	13	22	0	1214
16:45	14	306	15	0	39	46	35	0	32	525	113	1	7	23	21	0	1177
Total	66	1096	40	0	211	145	145	3	146	2074	454	1	38	75	87	0	4581
17:00	16	283	17	0	53	53	27	0	26	478	77	0	10	23	37	0	1100
17:15	17	313	17	0	33	37	22	0	24	475	99	0	8	15	29	0	1089
17:30	19	253	13	0	28	31	16	0	29	466	93	0	12	23	51	0	1034
17:45	8	281	7	0	25	32	19	0	38	484	93	0	10	11	32	0	1040
Total	60	1130	54	0	139	153	84	0	117	1903	362	0	40	72	149	0	4263
Grand Total	543	12421	260	0	2396	578	855	4	746	11242	2137	2	259	707	1155	2	33307
Apprch %	4.1	93.9	2	0	62.5	15.1	22.3	0.1	5.3	79.6	15.1	0	12.2	33.3	54.4	0.1	
Total %	1.6	37.3	0.8	0	7.2	1.7	2.6	0	2.2	33.8	6.4	0	0.8	2.1	3.5	0	

Alliant Engineering Inc Minneapolis, MN 55415

TH-65 at 93rd Ave NE / Clover Leaf Pkwy
 Ref.Pt.: 011.484
 data by Alliant Engineering Inc
 TURN MOVEMENT COUNT

File Name : TH-65 at 93rd Ave NE 2009
 Site Code : 00000013
 Start Date : 1/13/2009
 Page No : 3

Start Time	TH-65 Southbound					93rd Ave NE Westbound					TH-65 Northbound					Clover Leaf Pkwy NE Eastbound					Int. Total
	Left	Thru	Right	Peds	App. Total	Left	Thru	Right	Peds	App. Total	Left	Thru	Right	Peds	App. Total	Left	Thru	Right	Peds	App. Total	
Peak Hour Analysis From 06:00 to 08:45 - Peak 1 of 1																					
Peak Hour for Entire Intersection Begins at 06:45																					
06:45	9	424	1	0	434	112	1	8	0	121	3	128	44	0	175	4	38	49	0	91	821
07:00	6	437	0	0	443	99	1	9	0	109	11	109	39	0	159	0	28	53	0	81	792
07:15	5	407	1	0	413	94	3	4	0	101	16	151	32	0	199	0	26	54	2	82	795
07:30	6	442	1	0	449	102	2	13	0	117	9	179	36	0	224	3	25	62	0	90	880
Total Volume	26	1710	3	0	1739	407	7	34	0	448	39	567	151	0	757	7	117	218	2	344	3288
% App. Total	1.5	98.3	0.2	0		90.8	1.6	7.6	0		5.2	74.9	19.9	0		2	34	63.4	0.6		
PHF	.722	.967	.750	.000	.968	.908	.583	.654	.000	.926	.609	.792	.858	.000	.845	.438	.770	.879	.250	.945	.934

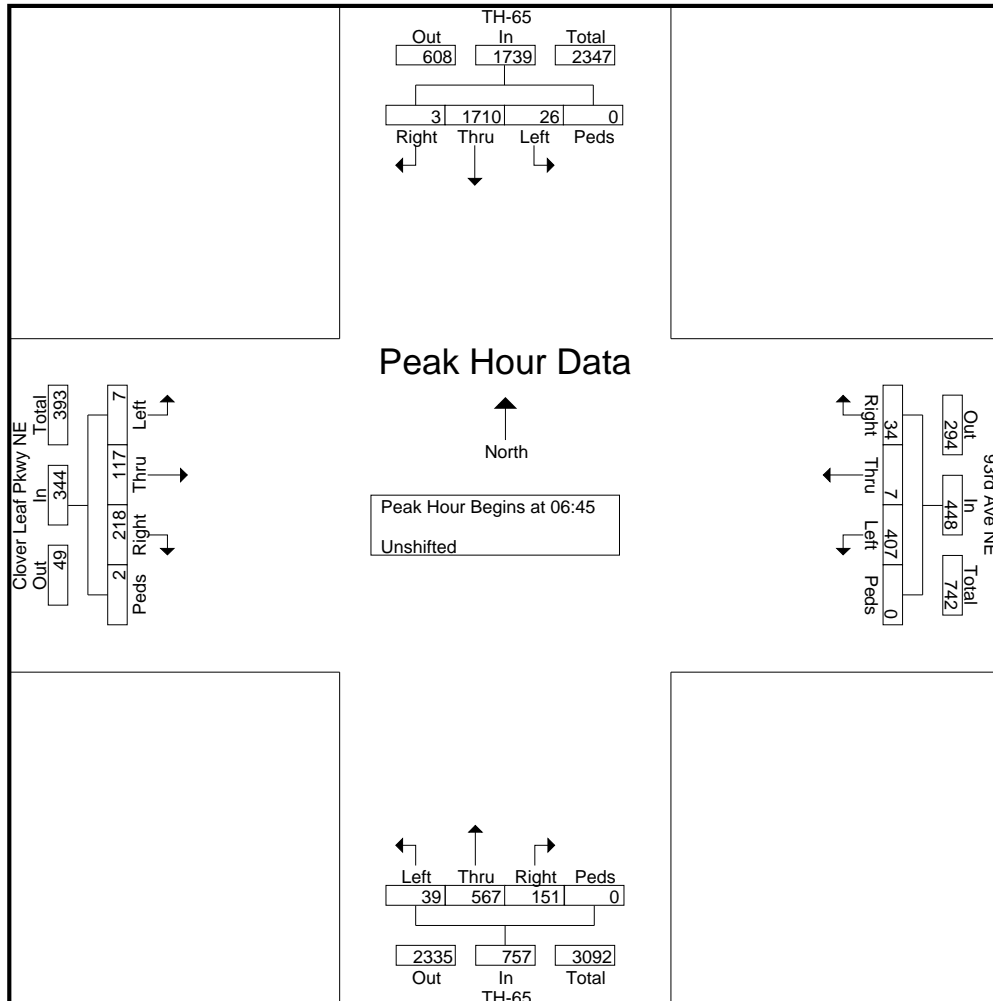

Alliant Engineering Inc Minneapolis, MN 55415

TH-65 at 93rd Ave NE / Clover Leaf Pkwy
 Ref.Pt.: 011.484
 data by Alliant Engineering Inc
 TURN MOVEMENT COUNT

File Name : TH-65 at 93rd Ave NE 2009
 Site Code : 00000013
 Start Date : 1/13/2009
 Page No : 4

Start Time	TH-65 Southbound					93rd Ave NE Westbound					TH-65 Northbound					Clover Leaf Pkwy NE Eastbound					Int. Total
	Left	Thru	Right	Peds	App. Total	Left	Thru	Right	Peds	App. Total	Left	Thru	Right	Peds	App. Total	Left	Thru	Right	Peds	App. Total	
Peak Hour Analysis From 15:00 to 17:45 - Peak 1 of 1																					
Peak Hour for Entire Intersection Begins at 16:15																					
16:15	15	246	10	0	271	56	32	37	0	125	46	517	113	0	676	8	21	26	0	55	1127
16:30	18	303	8	0	329	58	38	41	3	140	39	509	149	0	697	13	13	22	0	48	1214
16:45	14	306	15	0	335	39	46	35	0	120	32	525	113	1	671	7	23	21	0	51	1177
17:00	16	283	17	0	316	53	53	27	0	133	26	478	77	0	581	10	23	37	0	70	1100
Total Volume	63	1138	50	0	1251	206	169	140	3	518	143	2029	452	1	2625	38	80	106	0	224	4618
% App. Total	5	91	4	0		39.8	32.6	27	0.6		5.4	77.3	17.2	0		17	35.7	47.3	0		
PHF	.875	.930	.735	.000	.934	.888	.797	.854	.250	.925	.777	.966	.758	.250	.942	.731	.870	.716	.000	.800	.951

