



MINNESOTA DEPT OF TRANSPORTATION

TRAFFIC DATA COLLECTION - METRO

TH-7 at TH-41
 ref.pt.: 181.951
 collected by: ALLIANT CONSULT.
 Turn Movement Count

File Name : TH-7 at TH-41 2007
 Site Code : 00000141
 Start Date : 11/14/2007
 Page No : 1

Groups Printed- Cars & Trucks

Start Time	TH-41 Southbound				TH-7 Westbound				TH-41 Northbound				TH-7 Eastbound				Int. Total
	Left	Thru	Right	Peds	Left	Thru	Right	Peds	Left	Thru	Right	Peds	Left	Thru	Right	Peds	
06:00	0	0	0	0	21	21	2	0	4	6	52	0	0	0	0	0	106
06:15	7	12	1	0	29	31	5	0	1	6	45	0	6	151	8	0	302
06:30	14	21	0	0	43	52	10	0	4	12	90	0	5	207	20	0	478
06:45	14	28	2	0	34	47	12	0	17	27	80	0	6	234	44	0	545
Total	35	61	3	0	127	151	29	0	26	51	267	0	17	592	72	0	1431
07:00	16	17	2	0	53	62	9	0	13	23	106	0	11	301	29	0	642
07:15	20	25	3	0	43	71	7	0	16	26	118	0	15	313	40	0	697
07:30	24	36	6	0	75	78	7	0	15	23	121	0	13	294	65	1	758
07:45	21	39	6	0	90	64	13	0	15	32	106	0	9	251	49	0	695
Total	81	117	17	0	261	275	36	0	59	104	451	0	48	1159	183	1	2792
08:00	16	41	3	0	94	64	20	0	16	29	112	0	12	192	55	0	654
08:15	15	31	7	0	84	62	12	0	33	39	141	0	6	185	48	0	663
08:30	17	32	2	0	79	61	15	0	24	39	109	0	7	165	48	0	598
08:45	21	37	5	0	70	70	20	0	19	32	70	0	17	137	31	0	529
Total	69	141	17	0	327	257	67	0	92	139	432	0	42	679	182	0	2444
09:00	12	40	3	0	81	63	15	0	29	36	106	1	13	154	38	0	591
09:15	20	41	4	0	46	68	26	0	23	27	81	0	12	100	32	0	480
09:30	16	29	10	0	0	0	0	0	0	0	0	0	10	108	23	0	196
*** BREAK ***																	
Total	48	110	17	0	127	131	41	0	52	63	187	1	35	362	93	0	1267
*** BREAK ***																	
10:30	14	19	11	0	34	63	19	0	21	18	32	0	7	97	16	0	351
10:45	27	31	7	0	38	67	16	0	17	22	48	0	10	75	13	0	371
Total	41	50	18	0	72	130	35	0	38	40	80	0	17	172	29	0	722
11:00	13	23	12	0	40	66	26	0	19	21	42	0	12	97	16	0	387
11:15	33	29	10	0	47	69	17	0	14	25	61	0	6	79	16	0	406
11:30	14	16	8	0	46	77	13	0	16	23	21	0	8	95	7	0	344
11:45	16	33	12	0	65	75	27	0	23	33	48	0	7	89	13	0	441
Total	76	101	42	0	198	287	83	0	72	102	172	0	33	360	52	0	1578
12:00	27	21	7	0	44	78	16	0	16	27	64	0	11	78	16	0	405
12:15	23	30	12	0	38	84	27	0	14	37	45	0	7	68	7	0	392
12:30	18	25	11	0	44	76	22	0	16	23	38	0	1	75	15	0	364
12:45	17	26	4	0	60	75	22	0	22	26	42	0	7	72	18	0	391
Total	85	102	34	0	186	313	87	0	68	113	189	0	26	293	56	0	1552
13:00	21	20	10	0	40	54	21	0	19	21	26	0	5	60	5	0	302
13:15	24	28	10	0	46	89	37	0	22	26	55	0	8	59	21	0	425
*** BREAK ***																	
Total	45	48	20	0	86	143	58	0	41	47	81	0	13	119	26	0	727
*** BREAK ***																	
14:30	18	39	23	0	89	115	33	1	38	40	78	0	10	92	25	0	601
14:45	14	25	19	0	104	151	41	0	23	30	65	0	8	84	16	0	580
Total	32	64	42	0	193	266	74	1	61	70	143	0	18	176	41	0	1181
15:00	23	30	25	0	58	210	43	0	45	45	95	0	13	98	18	0	703
15:15	16	29	26	0	95	202	31	0	34	49	64	0	12	110	15	0	683
15:30	19	31	25	0	98	196	38	0	43	38	65	0	16	104	29	0	702
15:45	13	41	25	0	112	200	48	0	32	42	97	0	11	100	34	0	755
Total	71	131	101	0	363	808	160	0	154	174	321	0	52	412	96	0	2843



MINNESOTA DEPT OF TRANSPORTATION

TRAFFIC DATA COLLECTION - METRO

TH-7 at TH-41
 ref.pt.: 181.951
 collected by: ALLIANT CONSULT.
 Turn Movement Count

File Name : TH-7 at TH-41 2007
 Site Code : 00000141
 Start Date : 11/14/2007
 Page No : 2

Groups Printed- Cars & Trucks

Start Time	TH-41 Southbound				TH-7 Westbound				TH-41 Northbound				TH-7 Eastbound				Int. Total
	Left	Thru	Right	Peds	Left	Thru	Right	Peds	Left	Thru	Right	Peds	Left	Thru	Right	Peds	
16:00	23	38	34	0	114	206	46	0	80	73	155	0	13	81	17	0	880
16:15	27	18	12	0	77	227	64	1	60	45	91	0	13	84	18	0	737
16:30	21	33	25	0	89	235	47	0	60	49	107	0	11	94	16	0	787
16:45	18	46	27	0	114	241	43	0	68	62	115	0	11	113	15	0	873
Total	89	135	98	0	394	909	200	1	268	229	468	0	48	372	66	0	3277
17:00	20	35	23	0	114	285	42	0	76	50	107	0	14	80	17	0	863
17:15	14	35	31	0	125	265	53	0	55	55	97	0	17	91	14	0	852
17:30	32	65	16	0	124	260	55	1	58	47	79	0	16	102	12	0	867
17:45	18	37	23	0	85	206	56	0	54	61	86	0	10	95	15	0	746
Total	84	172	93	0	448	1016	206	1	243	213	369	0	57	368	58	0	3328
Grand Total	756	1232	502	0	2782	4686	1076	3	1174	1345	3160	1	406	5064	954	1	23142
Apprch %	30.4	49.5	20.2	0	32.5	54.8	12.6	0	20.7	23.7	55.6	0	6.3	78.8	14.8	0	
Total %	3.3	5.3	2.2	0	12	20.2	4.6	0	5.1	5.8	13.7	0	1.8	21.9	4.1	0	



MINNESOTA DEPT OF TRANSPORTATION

TRAFFIC DATA COLLECTION - METRO

TH-7 at TH-41
 ref.pt.: 181.951
 collected by: ALLIANT CONSULT.
 Turn Movement Count

File Name : TH-7 at TH-41 2007
 Site Code : 00000141
 Start Date : 11/14/2007
 Page No : 3

Start Time	TH-41 Southbound					TH-7 Westbound					TH-41 Northbound					TH-7 Eastbound					Int. Total
	Left	Thru	Right	Peds	App. Total	Left	Thru	Right	Peds	App. Total	Left	Thru	Right	Peds	App. Total	Left	Thru	Right	Peds	App. Total	
Peak Hour Analysis From 06:00 to 12:00 - Peak 1 of 1																					
Peak Hour for Entire Intersection Begins at 07:15																					
07:15	20	25	3	0	48	43	71	7	0	121	16	26	118	0	160	15	313	40	0	368	697
07:30	24	36	6	0	66	75	78	7	0	160	15	23	121	0	159	13	294	65	0	373	758
07:45	21	39	6	0	66	90	64	13	0	167	15	32	106	0	153	9	251	49	0	309	695
08:00	16	41	3	0	60	94	64	20	0	178	16	29	112	0	157	12	192	55	0	259	654
Total Volume	81	141	18	0	240	302	277	47	0	626	62	110	457	0	629	49	1050	209	1	1309	2804
% App. Total	33.8	58.8	7.5	0		48.2	44.2	7.5	0		9.9	17.5	72.7	0		3.7	80.2	16	0.1		
PHF	.844	.860	.750	.000	.909	.803	.888	.588	.000	.879	.969	.859	.944	.000	.983	.817	.839	.804	.250	.877	.925

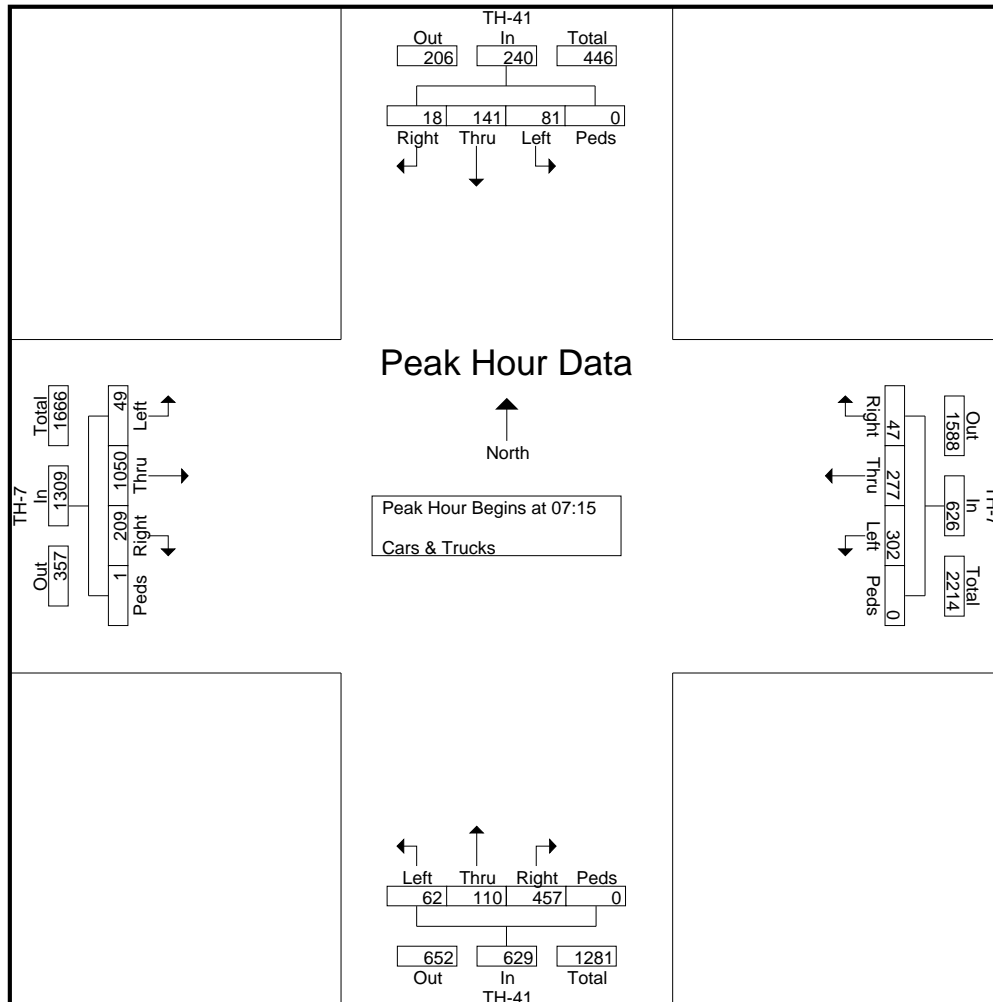



MINNESOTA DEPT OF TRANSPORTATION

TRAFFIC DATA COLLECTION - METRO

TH-7 at TH-41
 ref.pt.: 181.951
 collected by: ALLIANT CONSULT.
 Turn Movement Count

File Name : TH-7 at TH-41 2007
 Site Code : 00000141
 Start Date : 11/14/2007
 Page No : 4

Start Time	TH-41 Southbound					TH-7 Westbound					TH-41 Northbound					TH-7 Eastbound					Int. Total
	Left	Thru	Right	Peds	App. Total	Left	Thru	Right	Peds	App. Total	Left	Thru	Right	Peds	App. Total	Left	Thru	Right	Peds	App. Total	
Peak Hour Analysis From 14:30 to 17:45 - Peak 1 of 1																					
Peak Hour for Entire Intersection Begins at 16:45																					
16:45	18	46	27	0	91	114	241	43	0	398	68	62	115	0	245	11	113	15	0	139	873
17:00	20	35	23	0	78	114	285	42	0	441	76	50	107	0	233	14	80	17	0	111	863
17:15	14	35	31	0	80	125	265	53	0	443	55	55	97	0	207	17	91	14	0	122	852
17:30	32	65	16	0	113	124	260	55	1	440	58	47	79	0	184	16	102	12	0	130	867
Total Volume	84	181	97	0	362	477	1051	193	1	1722	257	214	398	0	869	58	386	58	0	502	3455
% App. Total	23.2	50	26.8	0		27.7	61	11.2	0.1		29.6	24.6	45.8	0		11.6	76.9	11.6	0		
PHF	.656	.696	.782	.000	.801	.954	.922	.877	.250	.972	.845	.863	.865	.000	.887	.853	.854	.853	.000	.903	.989

