

Alliant Engineering Inc Minneapolis, MN 55415

TH-7 at TH-41 / Hazeltine Blvd.
Ref.Pt.: 181.940
Alliant Engineering Inc
TURN MOVEMENT COUNT

File Name : 1_TH 7 at TH 41_020211
Site Code : 00000001
Start Date : 2/2/2011
Page No : 1

Groups Printed- Unshifted - Bank 1

Start Time	Lake Linden Drive Southbound				TH-7 Westbound				TH-41 / Hazeltine Blvd Northbound				TH-7 Eastbound				Int. Total
	Left	Thru	Right	Peds	Left	Thru	Right	Peds	Left	Thru	Right	Peds	Left	Thru	Right	Peds	
06:00	5	14	3	0	17	14	1	0	3	4	32	0	4	90	5	0	192
06:15	7	15	4	0	31	26	3	0	5	8	48	0	4	145	18	0	314
06:30	4	10	8	0	35	20	3	0	4	9	62	0	2	198	16	0	371
06:45	10	23	4	0	29	36	8	0	11	11	80	0	8	195	20	0	435
Total	26	62	19	0	112	96	15	0	23	32	222	0	18	628	59	0	1312
07:00	16	27	3	0	29	55	8	0	8	6	98	0	4	218	25	0	497
07:15	16	36	4	0	55	42	3	0	4	16	140	0	8	229	39	0	592
07:30	20	38	5	0	57	60	16	0	14	29	168	0	4	334	64	0	809
07:45	15	34	1	0	78	72	9	0	10	15	148	0	15	214	49	0	660
Total	67	135	13	0	219	229	36	0	36	66	554	0	31	995	177	0	2558
08:00	14	27	2	0	77	54	9	0	10	24	96	0	7	178	39	0	537
08:15	11	38	3	0	54	33	9	0	25	25	88	0	10	148	36	0	480
08:30	13	43	5	0	66	59	11	0	15	34	55	0	9	97	48	0	455
08:45	16	43	5	0	93	48	13	0	27	33	71	0	13	134	41	0	537
Total	54	151	15	0	290	194	42	0	77	116	310	0	39	557	164	0	2009
09:00	15	39	0	0	95	43	15	0	38	42	107	0	1	117	61	0	573
09:15	9	36	5	0	74	45	14	0	15	22	53	0	3	112	30	0	418
*** BREAK ***																	
Total	24	75	5	0	169	88	29	0	53	64	160	0	4	229	91	0	991
*** BREAK ***																	
10:30	13	27	0	0	19	39	9	0	13	18	41	0	2	60	18	1	260
10:45	20	25	2	0	28	45	10	0	20	37	44	0	7	53	7	0	298
Total	33	52	2	0	47	84	19	0	33	55	85	0	9	113	25	1	558
11:00	18	20	4	0	35	39	7	0	15	19	38	0	2	60	15	0	272
11:15	17	23	4	0	45	38	9	0	24	25	78	0	5	73	15	0	356
11:30	24	28	6	0	38	44	12	0	28	23	58	0	4	67	16	0	348
11:45	14	22	2	0	38	74	17	0	24	30	33	0	4	76	12	0	346
Total	73	93	16	0	156	195	45	0	91	97	207	0	15	276	58	0	1322
12:00	54	34	7	0	54	44	8	0	18	29	37	0	9	58	16	0	368
12:15	17	26	13	0	34	56	7	0	19	24	34	0	2	67	14	0	313
12:30	18	20	6	0	40	58	20	0	41	25	33	0	8	65	22	0	356
12:45	21	53	7	0	53	56	16	0	17	29	39	0	8	58	19	0	376
Total	110	133	33	0	181	214	51	0	95	107	143	0	27	248	71	0	1413
13:00	13	32	7	0	63	51	12	0	15	23	40	0	7	64	28	0	355
13:15	19	30	11	0	64	75	14	0	12	22	44	0	13	74	14	0	392
*** BREAK ***																	
Total	32	62	18	0	127	126	26	0	27	45	84	0	20	138	42	0	747
*** BREAK ***																	
14:30	14	22	8	0	59	98	21	0	18	54	65	0	14	72	11	0	456
14:45	19	27	6	0	77	109	28	0	25	35	61	0	4	71	21	0	483
Total	33	49	14	0	136	207	49	0	43	89	126	0	18	143	32	0	939
15:00	17	31	12	0	60	133	23	0	59	24	54	0	7	68	20	0	508
15:15	10	40	8	0	76	125	20	0	45	68	49	0	13	57	22	0	533
15:30	13	31	12	0	62	115	31	0	40	54	74	0	12	64	26	0	534
15:45	12	59	11	0	89	134	16	0	26	57	59	0	9	69	23	0	564
Total	52	161	43	0	287	507	90	0	170	203	236	0	41	258	91	0	2139

Alliant Engineering Inc Minneapolis, MN 55415

TH-7 at TH-41 / Hazeltine Blvd.
 Ref.Pt.: 181.940
 Alliant Engineering Inc
 TURN MOVEMENT COUNT

File Name : 1_TH 7 at TH 41_020211
 Site Code : 00000001
 Start Date : 2/2/2011
 Page No : 2

Groups Printed- Unshifted - Bank 1

Start Time	Lake Linden Drive Southbound				TH-7 Westbound				TH-41 / Hazeltine Blvd Northbound				TH-7 Eastbound				Int. Total
	Left	Thru	Right	Peds	Left	Thru	Right	Peds	Left	Thru	Right	Peds	Left	Thru	Right	Peds	
16:00	18	24	16	0	90	106	25	0	61	45	112	0	5	50	26	0	578
16:15	24	33	17	0	58	164	41	0	60	69	81	0	8	75	14	0	644
16:30	21	27	15	0	73	180	27	0	41	56	62	0	8	64	25	0	599
16:45	24	39	15	0	65	176	41	0	46	64	58	0	6	74	21	0	629
Total	87	123	63	0	286	626	134	0	208	234	313	0	27	263	86	0	2450
17:00	22	42	19	0	122	153	14	0	68	29	82	0	3	57	24	0	635
17:15	24	46	33	0	111	202	23	0	67	72	85	0	5	61	27	1	757
17:30	25	32	24	0	91	212	34	0	62	48	83	0	7	60	22	0	700
17:45	23	47	16	0	68	202	25	0	60	44	96	0	7	72	23	0	683
Total	94	167	92	0	392	769	96	0	257	193	346	0	22	250	96	1	2775
Grand Total	685	1263	333	0	2402	3335	632	0	1113	1301	2786	0	271	4098	992	2	19213
Apprch %	30	55.4	14.6	0	37.7	52.4	9.9	0	21.4	25	53.6	0	5.1	76.4	18.5	0	
Total %	3.6	6.6	1.7	0	12.5	17.4	3.3	0	5.8	6.8	14.5	0	1.4	21.3	5.2	0	
Unshifted	678	1245	331	0	2334	3271	621	0	1076	1287	2703	0	263	4023	958	2	18792
% Unshifted	99	98.6	99.4	0	97.2	98.1	98.3	0	96.7	98.9	97	0	97	98.2	96.6	100	97.8
Bank 1	7	18	2	0	68	64	11	0	37	14	83	0	8	75	34	0	421
% Bank 1	1	1.4	0.6	0	2.8	1.9	1.7	0	3.3	1.1	3	0	3	1.8	3.4	0	2.2

Alliant Engineering Inc Minneapolis, MN 55415

TH-7 at TH-41 / Hazeltine Blvd.
Ref.Pt.: 181.940
Alliant Engineering Inc
TURN MOVEMENT COUNT

File Name : 1_TH 7 at TH 41_020211
Site Code : 00000001
Start Date : 2/2/2011
Page No : 3

Start Time	Lake Linden Drive Southbound					TH-7 Westbound					TH-41 / Hazeltine Blvd Northbound					TH-7 Eastbound					Int. Total
	Left	Thru	Right	Peds	App. Total	Left	Thru	Right	Peds	App. Total	Left	Thru	Right	Peds	App. Total	Left	Thru	Right	Peds	App. Total	
Peak Hour Analysis From 06:00 to 09:15 - Peak 1 of 1																					
Peak Hour for Entire Intersection Begins at 07:15																					
07:15	16	36	4	0	56	55	42	3	0	100	4	16	140	0	160	8	229	39	0	276	592
07:30	20	38	5	0	63	57	60	16	0	133	14	29	168	0	211	4	334	64	0	402	809
07:45	15	34	1	0	50	78	72	9	0	159	10	15	148	0	173	15	214	49	0	278	660
08:00	14	27	2	0	43	77	54	9	0	140	10	24	96	0	130	7	178	39	0	224	537
Total Volume	65	135	12	0	212	267	228	37	0	532	38	84	552	0	674	34	955	191	0	1180	2598
% App. Total	30.7	63.7	5.7	0		50.2	42.9	7	0		5.6	12.5	81.9	0		2.9	80.9	16.2	0		
PHF	.813	.888	.600	.000	.841	.856	.792	.578	.000	.836	.679	.724	.821	.000	.799	.567	.715	.746	.000	.734	.803

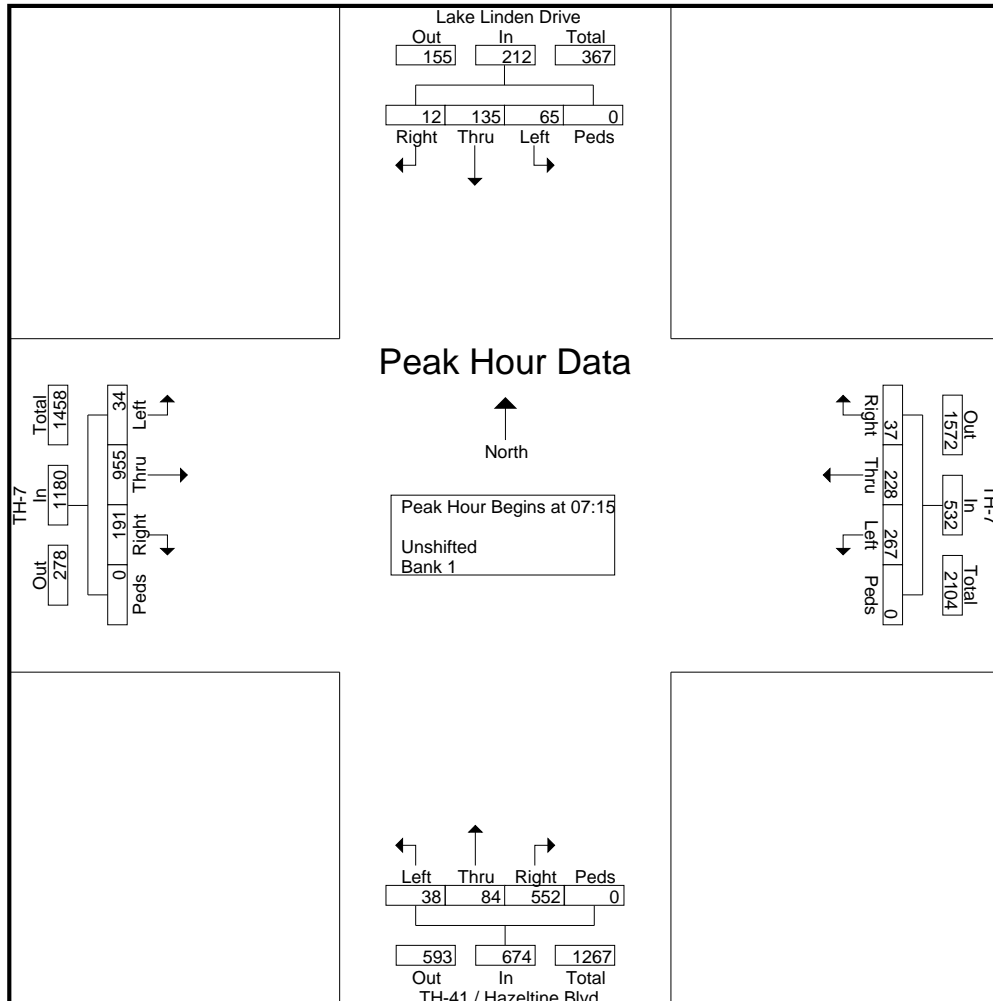

Alliant Engineering Inc Minneapolis, MN 55415

TH-7 at TH-41 / Hazeltine Blvd.
Ref.Pt.: 181.940
Alliant Engineering Inc
TURN MOVEMENT COUNT

File Name : 1_TH 7 at TH 41_020211
Site Code : 00000001
Start Date : 2/2/2011
Page No : 4

Start Time	Lake Linden Drive Southbound					TH-7 Westbound					TH-41 / Hazeltine Blvd Northbound					TH-7 Eastbound					Int. Total
	Left	Thru	Right	Peds	App. Total	Left	Thru	Right	Peds	App. Total	Left	Thru	Right	Peds	App. Total	Left	Thru	Right	Peds	App. Total	
Peak Hour Analysis From 14:30 to 17:45 - Peak 1 of 1																					
Peak Hour for Entire Intersection Begins at 17:00																					
17:00	22	42	19	0	83	122	153	14	0	289	68	29	82	0	179	3	57	24	0	84	635
17:15	24	46	33	0	103	111	202	23	0	336	67	72	85	0	224	5	61	27	1	94	757
17:30	25	32	24	0	81	91	212	34	0	337	62	48	83	0	193	7	60	22	0	89	700
17:45	23	47	16	0	86	68	202	25	0	295	60	44	96	0	200	7	72	23	0	102	683
Total Volume	94	167	92	0	353	392	769	96	0	1257	257	193	346	0	796	22	250	96	1	369	2775
% App. Total	26.6	47.3	26.1	0		31.2	61.2	7.6	0		32.3	24.2	43.5	0		6	67.8	26	0.3		
PHF	.940	.888	.697	.000	.857	.803	.907	.706	.000	.932	.945	.670	.901	.000	.888	.786	.868	.889	.250	.904	.916

