



MINNESOTA DEPT OF TRANSPORTATION

TRAFFIC DATA COLLECTION - METRO

CSAH-101 at Excelsior Blvd.
 ref.pt.:
 Counter: Ken Levin - ALLIANT CONSULT.
 Turn Movement Count

File Name : CSAH-101 at Excelsior Blvd 2007
 Site Code : 00000155
 Start Date : 12/5/2007
 Page No : 1

Groups Printed- Cars & Trucks

Start Time	CSAH-101 Southbound				Excelsior Blvd Westbound				CSAH-101 Northbound				Excelsior Blvd Eastbound				Int. Total
	Left	Thru	Right	Peds	Left	Thru	Right	Peds	Left	Thru	Right	Peds	Left	Thru	Right	Peds	
06:00	8	16	5	0	1	3	9	0	0	27	6	0	6	1	0	0	82
06:15	8	24	9	0	3	5	11	0	3	42	6	0	5	4	3	0	123
06:30	13	21	11	0	6	10	21	0	14	55	10	0	10	4	5	0	180
06:45	22	36	28	0	7	27	16	0	16	56	24	0	14	11	4	0	261
Total	51	97	53	0	17	45	57	0	33	180	46	0	35	20	12	0	646
07:00	29	45	28	2	9	30	17	0	18	76	20	0	29	18	26	0	347
07:15	33	57	22	1	5	24	28	0	29	87	19	0	33	25	25	0	388
07:30	45	52	27	2	5	49	20	0	56	109	25	0	43	34	23	0	490
07:45	43	51	39	0	11	20	10	0	23	94	22	0	39	25	38	0	415
Total	150	205	116	5	30	123	75	0	126	366	86	0	144	102	112	0	1640
08:00	40	73	5	0	11	20	22	0	5	103	15	0	36	39	46	0	415
08:15	47	62	5	0	13	7	18	0	4	83	12	0	17	24	10	0	302
08:30	25	67	1	0	8	13	45	0	4	125	22	0	13	14	6	0	343
08:45	40	51	6	0	8	9	27	0	4	64	14	0	10	6	3	0	242
Total	152	253	17	0	40	49	112	0	17	375	63	0	76	83	65	0	1302
09:00	30	47	6	0	9	5	34	0	5	80	19	0	9	16	11	0	271
09:15	34	52	7	0	8	8	36	0	4	78	4	0	10	7	3	0	251
*** BREAK ***																	
Total	64	99	13	0	17	13	70	0	9	158	23	0	19	23	14	0	522
*** BREAK ***																	
10:30	32	49	4	0	3	6	25	0	4	41	6	0	10	2	4	0	186
10:45	35	57	3	0	8	3	23	0	2	50	4	0	7	2	3	0	197
Total	67	106	7	0	11	9	48	0	6	91	10	0	17	4	7	0	383
11:00	31	50	5	0	10	12	31	0	1	63	8	0	5	9	8	0	233
11:15	34	55	5	0	4	17	36	0	6	80	19	0	6	9	10	0	281
11:30	31	55	2	0	5	11	40	0	4	51	12	0	8	7	4	0	230
11:45	44	57	5	0	9	12	23	0	4	49	10	0	14	7	3	0	237
Total	140	217	17	0	28	52	130	0	15	243	49	0	33	32	25	0	981
12:00	38	51	7	0	11	11	36	0	8	57	6	0	17	6	4	0	252
12:15	42	44	9	0	11	5	44	0	9	57	11	0	8	14	10	0	264
12:30	41	70	8	0	13	11	49	0	11	71	14	0	10	5	3	0	306
12:45	33	79	8	0	9	4	31	0	2	77	10	0	7	11	3	0	274
Total	154	244	32	0	44	31	160	0	30	262	41	0	42	36	20	0	1096
13:00	50	63	9	0	10	5	45	0	5	57	8	0	7	7	6	0	272
13:15	24	53	4	0	18	12	35	0	0	62	7	0	6	11	8	0	240
*** BREAK ***																	
Total	74	116	13	0	28	17	80	0	5	119	15	0	13	18	14	0	512
*** BREAK ***																	
14:30	34	81	12	0	8	12	37	0	9	73	9	0	16	7	10	0	308
14:45	49	51	10	0	1	12	39	0	14	60	6	0	48	26	33	0	349
Total	83	132	22	0	9	24	76	0	23	133	15	0	64	33	43	0	657
15:00	65	72	5	0	16	21	36	0	12	85	7	0	38	43	42	0	442
15:15	53	100	4	0	15	20	55	0	5	100	20	0	16	10	14	0	412
15:30	55	85	10	0	13	17	52	0	16	112	15	0	19	11	9	0	414
15:45	56	79	8	0	21	10	58	0	7	107	14	0	16	23	16	0	415
Total	229	336	27	0	65	68	201	0	40	404	56	0	89	87	81	0	1683



MINNESOTA DEPT OF TRANSPORTATION

TRAFFIC DATA COLLECTION - METRO

CSAH-101 at Excelsior Blvd.
 ref.pt.:
 Counter: Ken Levin - ALLIANT CONSULT.
 Turn Movement Count

File Name : CSAH-101 at Excelsior Blvd 2007
 Site Code : 00000155
 Start Date : 12/5/2007
 Page No : 2

Groups Printed- Cars & Trucks

Start Time	CSAH-101 Southbound				Excelsior Blvd Westbound				CSAH-101 Northbound				Excelsior Blvd Eastbound				Int. Total
	Left	Thru	Right	Peds	Left	Thru	Right	Peds	Left	Thru	Right	Peds	Left	Thru	Right	Peds	
16:00	30	98	7	0	23	21	60	0	6	92	10	0	24	13	12	0	396
16:15	57	121	15	0	28	21	84	0	9	103	18	0	13	14	9	0	492
16:30	54	109	12	0	29	24	61	0	12	117	19	0	16	21	16	0	490
16:45	55	104	13	0	46	28	81	0	22	128	12	0	22	15	11	0	537
Total	196	432	47	0	126	94	286	0	49	440	59	0	75	63	48	0	1915
17:00	34	114	29	0	32	24	83	0	13	124	16	0	18	17	8	0	512
17:15	39	106	30	0	26	42	77	0	15	123	12	0	19	17	12	0	518
17:30	46	113	32	0	33	25	90	0	22	128	9	0	20	16	6	0	540
17:45	48	119	43	0	17	22	82	0	16	129	16	0	12	13	8	0	525
Total	167	452	134	0	108	113	332	0	66	504	53	0	69	63	34	0	2095
Grand Total	1527	2689	498	5	523	638	1627	0	419	3275	516	0	676	564	475	0	13432
Apprch %	32.4	57	10.6	0.1	18.8	22.9	58.4	0	10	77.8	12.3	0	39.4	32.9	27.7	0	
Total %	11.4	20	3.7	0	3.9	4.7	12.1	0	3.1	24.4	3.8	0	5	4.2	3.5	0	



MINNESOTA DEPT OF TRANSPORTATION

TRAFFIC DATA COLLECTION - METRO

CSAH-101 at Excelsior Blvd.
 ref.pt.:
 Counter: Ken Levin - ALLIANT CONSULT.
 Turn Movement Count

File Name : CSAH-101 at Excelsior Blvd 2007
 Site Code : 00000155
 Start Date : 12/5/2007
 Page No : 3

Start Time	CSAH-101 Southbound					Excelsior Blvd Westbound					CSAH-101 Northbound					Excelsior Blvd Eastbound					Int. Total
	Left	Thru	Right	Peds	App. Total	Left	Thru	Right	Peds	App. Total	Left	Thru	Right	Peds	App. Total	Left	Thru	Right	Peds	App. Total	
Peak Hour Analysis From 06:00 to 08:45 - Peak 1 of 1																					
Peak Hour for Entire Intersection Begins at 07:15																					
07:15	33	57	22	1	113	5	24	28	0	57	29	87	19	0	135	33	25	25	0	83	388
07:30	45	52	27	2	126	5	49	20	0	74	56	109	25	0	190	43	34	23	0	100	490
07:45	43	51	39	0	133	11	20	10	0	41	23	94	22	0	139	39	25	38	0	102	415
08:00	40	73	5	0	118	11	20	22	0	53	5	103	15	0	123	36	39	46	0	121	415
Total Volume	161	233	93	3	490	32	113	80	0	225	113	393	81	0	587	151	123	132	0	406	1708
% App. Total																					
PHF	.894	.798	.596	.375	.921	.727	.577	.714	.000	.760	.504	.901	.810	.000	.772	.878	.788	.717	.000	.839	.871

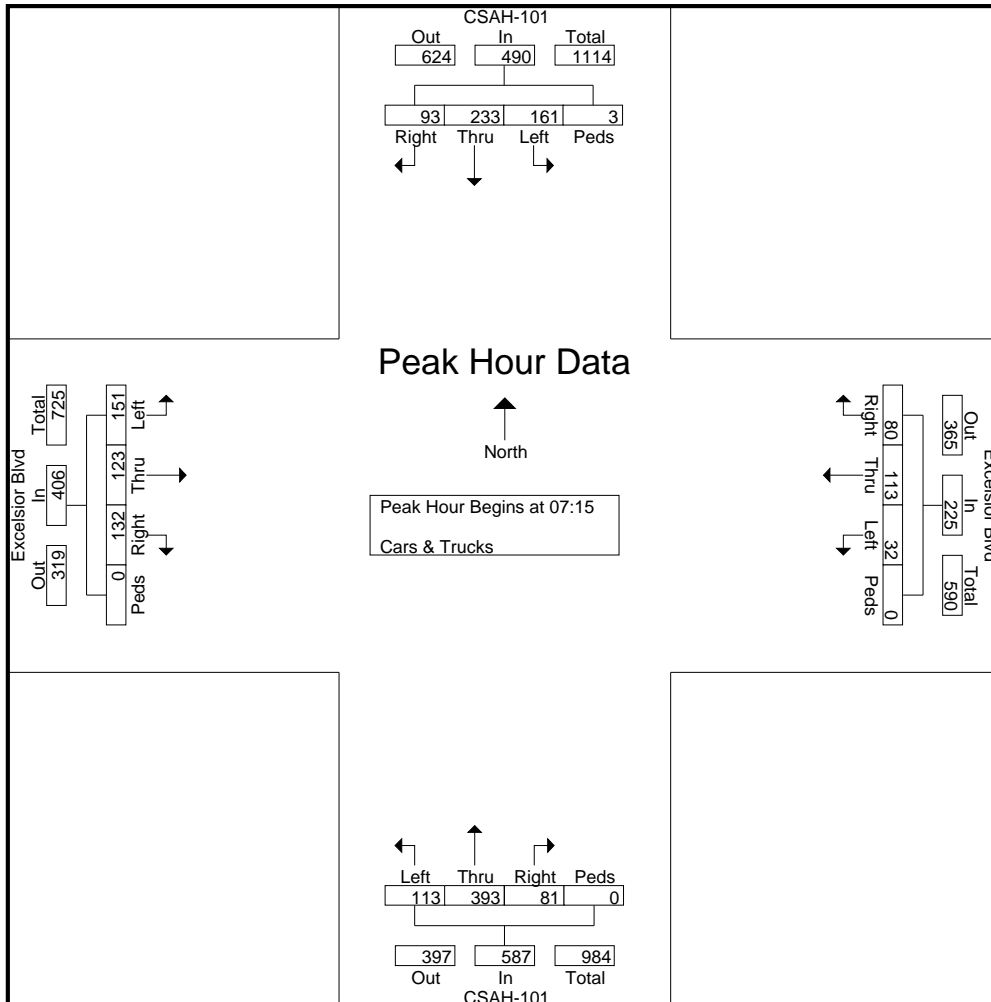



MINNESOTA DEPT OF TRANSPORTATION

TRAFFIC DATA COLLECTION - METRO

CSAH-101 at Excelsior Blvd.
 ref.pt.:
 Counter: Ken Levin - ALLIANT CONSULT.
 Turn Movement Count

File Name : CSAH-101 at Excelsior Blvd 2007
 Site Code : 00000155
 Start Date : 12/5/2007
 Page No : 4

Start Time	CSAH-101 Southbound					Excelsior Blvd Westbound					CSAH-101 Northbound					Excelsior Blvd Eastbound					Int. Total
	Left	Thru	Right	Peds	App. Total	Left	Thru	Right	Peds	App. Total	Left	Thru	Right	Peds	App. Total	Left	Thru	Right	Peds	App. Total	
Peak Hour Analysis From 15:00 to 17:45 - Peak 1 of 1																					
Peak Hour for Entire Intersection Begins at 16:45																					
16:45	55	104	13	0	172	46	28	81	0	155	22	128	12	0	162	22	15	11	0	48	537
17:00	34	114	29	0	177	32	24	83	0	139	13	124	16	0	153	18	17	8	0	43	512
17:15	39	106	30	0	175	26	42	77	0	145	15	123	12	0	150	19	17	12	0	48	518
17:30	46	113	32	0	191	33	25	90	0	148	22	128	9	0	159	20	16	6	0	42	540
Total Volume	174	437	104	0	715	137	119	331	0	587	72	503	49	0	624	79	65	37	0	181	2107
% App. Total	.791	.958	.813	.000	.936	.745	.708	.919	.000	.947	.818	.982	.766	.000	.963	.898	.956	.771	.000	.943	.975

