

TRAFFIC DATA INC.

3268 Xenwood Ave S
St Louis Park, MN 55416

TH-8 at Greenway Ave
Ref.Pt.: 002.058
TDI Inc
TURN MOVEMENT COUNT

File Name : 2681118 Hwy 8 & Greenway
Site Code : 2681118
Start Date : 3/1/2011
Page No : 1

Groups Printed- Class 1

Start Time	TH-8 / Lake Blvd Southbound				Greenway Ave Westbound				TH-8 / Lake Blvd Northbound				Greenway Ave Eastbound				Int. Total
	Left	Thru	Right	Peds	Left	Thru	Right	Peds	Left	Thru	Right	Peds	Left	Thru	Right	Peds	
06:00	0	192	16	0	34	2	2	0	3	23	0	0	1	0	26	0	299
06:15	2	292	19	0	36	4	3	0	2	34	1	0	0	0	21	0	414
06:30	3	207	18	0	40	1	3	0	6	52	5	0	0	0	16	0	351
06:45	2	266	7	0	58	4	6	0	14	66	2	0	3	3	11	0	442
Total	7	957	60	0	168	11	14	0	25	175	8	0	4	3	74	0	1506
07:00	1	296	24	0	48	5	4	0	8	58	2	0	0	0	18	0	464
07:15	3	248	20	0	54	2	4	0	10	82	5	0	1	1	21	0	451
07:30	4	256	15	0	40	6	6	0	8	108	4	1	1	0	18	0	467
07:45	2	212	14	0	33	5	8	0	16	106	3	1	3	1	14	0	418
Total	10	1012	73	0	175	18	22	0	42	354	14	2	5	2	71	0	1800
08:00	2	162	17	0	39	2	8	0	13	77	5	0	6	1	15	0	347
08:15	2	176	20	0	25	3	7	0	16	54	4	0	2	3	18	0	330
08:30	4	154	18	0	23	2	6	0	12	63	2	0	6	2	22	0	314
08:45	2	151	12	0	29	7	5	0	12	64	3	0	2	5	13	0	305
Total	10	643	67	0	116	14	26	0	53	258	14	0	16	11	68	0	1296
09:00	1	139	10	0	22	3	4	0	12	55	9	0	0	3	10	0	268
09:15	2	161	9	0	24	1	4	0	15	68	4	0	1	3	18	0	310
09:30	1	120	11	0	20	8	5	0	10	81	9	0	4	2	8	0	279
09:45	1	118	7	0	19	13	7	0	13	79	8	0	2	1	13	0	281
Total	5	538	37	0	85	25	20	0	50	283	30	0	7	9	49	0	1138
10:00	1	100	7	0	20	3	1	0	9	75	9	1	2	5	21	0	254
10:15	3	117	6	0	16	4	9	0	11	66	5	0	2	2	6	0	247
10:30	3	106	11	0	9	4	7	0	12	91	7	0	2	5	9	0	266
10:45	1	117	7	0	14	2	5	0	7	76	5	0	7	2	11	0	254
Total	8	440	31	0	59	13	22	0	39	308	26	1	13	14	47	0	1021
11:00	2	94	9	0	11	2	3	0	6	80	8	0	4	1	16	0	236
11:15	6	101	11	0	14	2	5	0	9	77	8	0	5	2	16	0	256
11:30	2	105	6	0	15	4	5	0	12	101	7	0	3	5	11	0	276
11:45	1	102	6	0	11	6	1	0	8	84	5	0	4	3	12	0	243
Total	11	402	32	0	51	14	14	0	35	342	28	0	16	11	55	0	1011
12:00	0	99	11	0	15	6	9	0	16	75	14	0	3	3	13	0	264
12:15	1	101	6	0	10	2	5	0	13	83	7	0	5	4	6	0	243
12:30	3	105	11	0	9	5	5	0	7	105	11	0	4	3	15	0	283
12:45	1	111	11	0	9	7	7	0	18	111	11	0	5	4	9	0	304
Total	5	416	39	0	43	20	26	0	54	374	43	0	17	14	43	0	1094
13:00	2	92	9	0	12	4	7	0	12	88	8	0	8	4	14	0	260
13:15	1	114	12	0	5	5	4	0	14	111	10	0	4	3	14	0	297
13:30	3	110	8	0	10	3	9	0	11	97	10	0	6	3	7	0	277
13:45	3	88	9	0	11	4	6	0	4	119	10	0	4	2	7	0	267
Total	9	404	38	0	38	16	26	0	41	415	38	0	22	12	42	0	1101
14:00	1	99	5	0	9	5	13	0	17	108	10	0	4	2	11	0	284
14:15	1	94	8	0	8	5	9	0	15	153	14	0	2	3	10	0	322
14:30	1	108	10	0	13	5	9	0	21	152	15	0	7	8	16	0	365
14:45	2	105	7	0	7	8	10	0	11	177	21	0	5	4	10	0	367
Total	5	406	30	0	37	23	41	0	64	590	60	0	18	17	47	0	1338
15:00	1	88	7	0	9	9	7	0	22	191	12	0	6	2	16	0	370
15:15	1	102	10	0	12	10	11	0	16	203	20	0	8	3	14	0	410
15:30	2	96	13	0	9	4	17	0	18	187	23	0	13	9	22	0	413

TRAFFIC DATA INC.

3268 Xenwood Ave S
St Louis Park, MN 55416

TH-8 at Greenway Ave
Ref.Pt.: 002.058
TDI Inc
TURN MOVEMENT COUNT

File Name : 2681118 Hwy 8 & Greenway
Site Code : 2681118
Start Date : 3/1/2011
Page No : 2

Groups Printed- Class 1

Start Time	TH-8 / Lake Blvd Southbound				Greenway Ave Westbound				TH-8 / Lake Blvd Northbound				Greenway Ave Eastbound				Int. Total
	Left	Thru	Rght	Peds	Left	Thru	Rght	Peds	Left	Thru	Rght	Peds	Left	Thru	Rght	Peds	
15:45	5	127	8	0	12	4	14	0	17	236	33	0	10	6	17	0	489
Total	9	413	38	0	42	27	49	0	73	817	88	0	37	20	69	0	1682
16:00	0	117	8	0	9	11	8	0	12	251	28	0	10	6	13	0	473
16:15	0	129	4	0	16	8	14	0	14	304	22	0	5	4	9	0	529
16:30	1	125	9	0	18	8	21	0	16	280	28	0	7	10	15	0	538
16:45	3	124	8	0	9	10	12	0	11	293	35	0	8	10	14	0	537
Total	4	495	29	0	52	37	55	0	53	1128	113	0	30	30	51	0	2077
17:00	2	138	7	0	12	8	22	0	12	282	37	0	11	7	11	3	552
17:15	4	137	9	0	7	8	16	0	11	271	30	0	10	5	13	0	521
17:30	6	110	3	0	15	6	14	0	12	270	33	0	8	7	9	0	493
17:45	5	96	2	0	11	4	12	0	11	235	32	0	6	7	9	0	430
Total	17	481	21	0	45	26	64	0	46	1058	132	0	35	26	42	3	1996
18:00	1	95	5	0	8	1	5	0	6	211	27	0	5	6	13	0	383
18:15	2	59	5	0	11	5	8	0	6	164	24	0	8	4	3	0	299
18:30	1	80	8	0	16	2	8	0	14	158	19	0	5	2	8	2	323
18:45	0	55	2	0	13	7	5	0	7	133	15	0	6	7	10	0	260
Total	4	289	20	0	48	15	26	0	33	666	85	0	24	19	34	2	1265
Grand Total	104	6896	515	0	959	259	405	0	608	6768	679	3	244	188	692	5	18325
Apprch %	1.4	91.8	6.9	0	59.1	16	25	0	7.5	84	8.4	0	21.6	16.7	61.3	0.4	
Total %	0.6	37.6	2.8	0	5.2	1.4	2.2	0	3.3	36.9	3.7	0	1.3	1	3.8	0	

TRAFFIC DATA INC.

3268 Xenwood Ave S
St Louis Park, MN 55416

TH-8 at Greenway Ave
Ref.Pt.: 002.058
TDI Inc
TURN MOVEMENT COUNT

File Name : 2681118 Hwy 8 & Greenway
Site Code : 2681118
Start Date : 3/1/2011
Page No : 3

Start Time	TH-8 / Lake Blvd Southbound					Greenway Ave Westbound					TH-8 / Lake Blvd Northbound					Greenway Ave Eastbound					Int. Total
	Left	Thru	Rght	Peds	App. Total	Left	Thru	Rght	Peds	App. Total	Left	Thru	Rght	Peds	App. Total	Left	Thru	Rght	Peds	App. Total	
Peak Hour Analysis From 06:00 to 09:30 - Peak 1 of 1																					
Peak Hour for Entire Intersection Begins at 06:45																					
06:45	2	266	7	0	275	58	4	6	0	68	14	66	2	0	82	3	3	11	0	17	442
07:00	1	296	24	0	321	48	5	4	0	57	8	58	2	0	68	0	0	18	0	18	464
07:15	3	248	20	0	271	54	2	4	0	60	10	82	5	0	97	1	1	21	0	23	451
07:30	4	256	15	0	275	40	6	6	0	52	8	108	4	1	121	1	0	18	0	19	467
Total Volume	10	1066	66	0	1142	200	17	20	0	237	40	314	13	1	368	5	4	68	0	77	1824
% App. Total	0.9	93.3	5.8	0		84.4	7.2	8.4	0		10.9	85.3	3.5	0.3		6.5	5.2	88.3	0		
PHF	.625	.900	.688	.000	.889	.862	.708	.833	.000	.871	.714	.727	.650	.250	.760	.417	.333	.810	.000	.837	.976

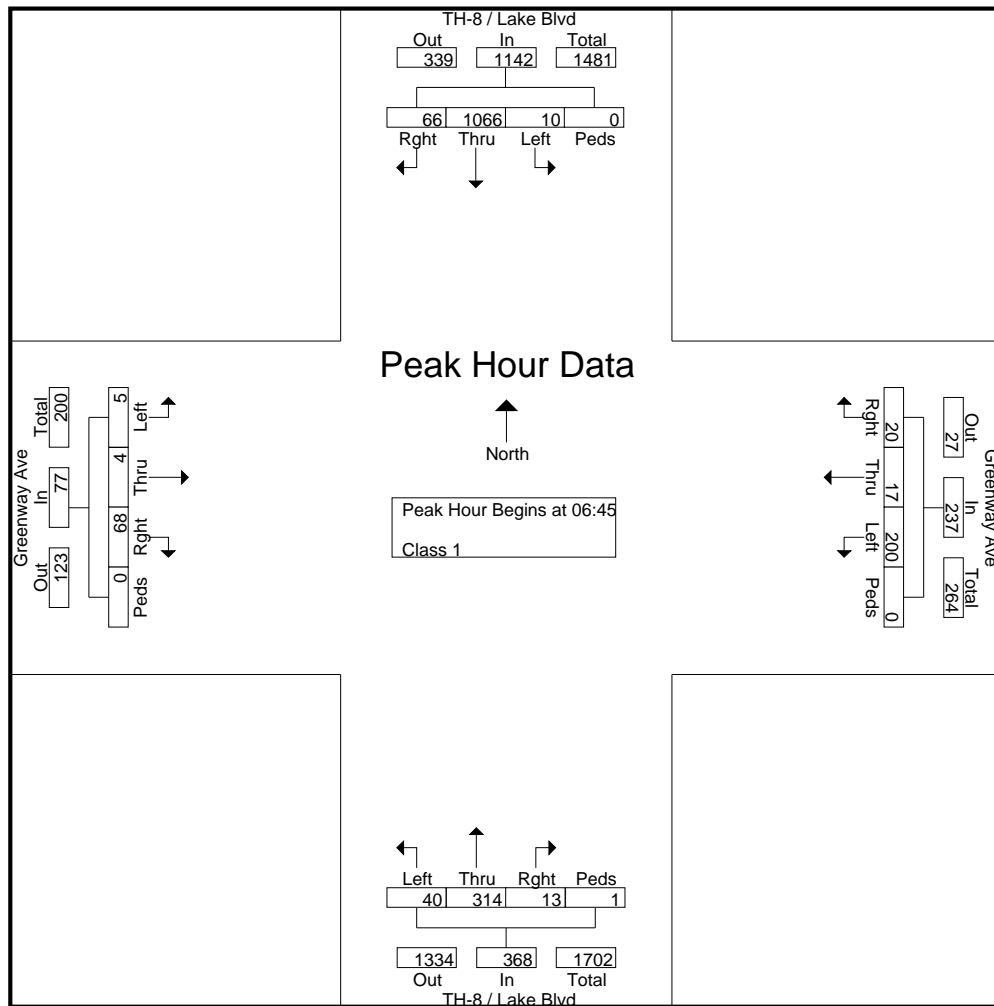

TRAFFIC DATA INC.

3268 Xenwood Ave S
St Louis Park, MN 55416

TH-8 at Greenway Ave
Ref.Pt.: 002.058
TDI Inc
TURN MOVEMENT COUNT

File Name : 2681118 Hwy 8 & Greenway
Site Code : 2681118
Start Date : 3/1/2011
Page No : 4

Start Time	TH-8 / Lake Blvd Southbound					Greenway Ave Westbound					TH-8 / Lake Blvd Northbound					Greenway Ave Eastbound					Int. Total
	Left	Thru	Rght	Peds	App. Total	Left	Thru	Rght	Peds	App. Total	Left	Thru	Rght	Peds	App. Total	Left	Thru	Rght	Peds	App. Total	
Peak Hour Analysis From 14:30 to 18:45 - Peak 1 of 1																					
Peak Hour for Entire Intersection Begins at 16:15																					
16:15	0	129	4	0	133	16	8	14	0	38	14	304	22	0	340	5	4	9	0	18	529
16:30	1	125	9	0	135	18	8	21	0	47	16	280	28	0	324	7	10	15	0	32	538
16:45	3	124	8	0	135	9	10	12	0	31	11	293	35	0	339	8	10	14	0	32	537
17:00	2	138	7	0	147	12	8	22	0	42	12	282	37	0	331	11	7	11	3	32	552
Total Volume	6	516	28	0	550	55	34	69	0	158	53	1159	122	0	1334	31	31	49	3	114	2156
% App. Total	1.1	93.8	5.1	0		34.8	21.5	43.7	0		4	86.9	9.1	0		27.2	27.2	43	2.6		
PHF	.500	.935	.778	.000	.935	.764	.850	.784	.000	.840	.828	.953	.824	.000	.981	.705	.775	.817	.250	.891	.976

