



MINNESOTA DEPT OF TRANSPORTATION

TRAFFIC DATA COLLECTION - METRO

TH-8 at 1st Ave / CSAH-14 NORTH BRANCH File Name : TH-8 at CSAH-14 NORTH BRANCH 2009
 Ref.Pt.: 055.543 Site Code : 00000000
 JAMAR #T2582 CR Start Date : 6/10/2009
 TURN MOVEMENT COUNT Page No : 1

Groups Printed- Cars & Trucks

Start Time	Grand Ave. Southbound				TH-8 / Main St. Westbound				1st Ave / CSAH-14 Northbound				TH-8 / Main St. Eastbound				Int. Total
	Left	Thru	Right	Peds	Left	Thru	Right	Peds	Left	Thru	Right	Peds	Left	Thru	Right	Peds	
06:00	1	1	0	0	0	35	0	0	29	0	1	0	0	7	9	0	83
06:15	0	2	0	0	3	39	0	0	33	1	0	2	0	11	20	0	111
06:30	1	0	1	0	1	25	0	0	21	5	0	3	0	15	17	0	89
06:45	0	3	1	0	4	48	1	0	43	2	0	2	1	14	24	0	143
Total	2	6	2	0	8	147	1	0	126	8	1	7	1	47	70	0	426
07:00	1	3	2	0	6	48	0	0	47	2	3	4	0	13	23	0	152
07:15	0	3	0	0	14	46	1	0	49	3	7	1	0	18	31	0	173
07:30	3	6	1	0	7	29	0	0	42	3	4	4	0	16	38	0	153
07:45	2	5	0	0	8	43	5	1	49	6	1	2	0	27	41	0	190
Total	6	17	3	0	35	166	6	1	187	14	15	11	0	74	133	0	668
08:00	0	5	2	0	4	34	0	0	39	2	1	4	0	14	26	0	131
08:15	3	6	0	0	13	47	0	0	62	4	4	2	0	17	40	0	198
08:30	1	1	2	0	4	32	0	1	42	0	3	3	0	18	34	0	141
08:45	2	3	1	0	11	29	1	2	52	3	7	3	0	19	32	0	165
Total	6	15	5	0	32	142	1	3	195	9	15	12	0	68	132	0	635
15:00	4	6	2	0	2	28	1	0	44	1	11	0	2	50	29	1	181
15:15	2	4	0	0	3	50	1	3	44	3	2	7	3	54	25	0	201
15:30	4	12	0	0	6	50	0	0	47	6	6	0	1	55	35	0	222
15:45	7	12	2	0	4	38	0	0	41	1	6	2	2	42	45	0	202
Total	17	34	4	0	15	166	2	3	176	11	25	9	8	201	134	1	806
16:00	5	4	0	0	3	46	1	0	50	5	1	0	1	59	36	0	211
16:15	11	9	2	0	6	39	0	0	47	3	3	2	0	52	56	0	230
16:30	5	13	2	0	0	62	0	0	51	2	5	0	0	69	47	0	256
16:45	2	14	0	0	5	43	1	0	51	2	11	0	1	76	50	1	257
Total	23	40	4	0	14	190	2	0	199	12	20	2	2	256	189	1	954
17:00	5	7	0	0	1	49	3	0	51	1	9	1	3	65	51	0	246
17:15	8	9	2	0	1	44	1	0	48	3	12	3	0	78	52	1	262
17:30	8	13	1	0	3	51	0	1	41	4	10	3	1	77	57	0	270
17:45	12	9	0	0	4	52	0	1	50	7	7	2	2	72	49	0	267
Total	33	38	3	0	9	196	4	2	190	15	38	9	6	292	209	1	1045
Grand Total	87	150	21	0	113	1007	16	9	1073	69	114	50	17	938	867	3	4534
Apprch %	33.7	58.1	8.1	0	9.9	87.9	1.4	0.8	82.2	5.3	8.7	3.8	0.9	51.4	47.5	0.2	
Total %	1.9	3.3	0.5	0	2.5	22.2	0.4	0.2	23.7	1.5	2.5	1.1	0.4	20.7	19.1	0.1	



MINNESOTA DEPT OF TRANSPORTATION

TRAFFIC DATA COLLECTION - METRO

TH-8 at 1st Ave / CSAH-14 NORTH BRANCH File Name : TH-8 at CSAH-14 NORTH BRANCH 2009
 Ref.Pt.: 055.543 Site Code : 00000000
 JAMAR #T2582 CR Start Date : 6/10/2009
 TURN MOVEMENT COUNT Page No : 2

Start Time	Grand Ave. Southbound					TH-8 / Main St. Westbound					1st Ave / CSAH-14 Northbound					TH-8 / Main St. Eastbound					Int. Total
	Left	Thru	Right	Peds	App. Total	Left	Thru	Right	Peds	App. Total	Left	Thru	Right	Peds	App. Total	Left	Thru	Right	Peds	App. Total	
Peak Hour Analysis From 06:00 to 08:45 - Peak 1 of 1																					
Peak Hour for Entire Intersection Begins at 07:30																					
07:30	3	6	1	0	10	7	29	0	0	36	42	3	4	4	53	0	16	38	0	54	153
07:45	2	5	0	0	7	8	43	5	1	57	49	6	1	2	58	0	27	41	0	68	190
08:00	0	5	2	0	7	4	34	0	0	38	39	2	1	4	46	0	14	26	0	40	131
08:15	3	6	0	0	9	13	47	0	0	60	62	4	4	2	72	0	17	40	0	57	198
Total Volume	8	22	3	0	33	32	153	5	1	191	192	15	10	12	229	0	74	145	0	219	672
% App. Total	24.2	66.7	9.1	0		16.8	80.1	2.6	0.5		83.8	6.6	4.4	5.2		0	33.8	66.2	0		
PHF	.667	.917	.375	.000	.825	.615	.814	.250	.250	.796	.774	.625	.625	.750	.795	.000	.685	.884	.000	.805	.848

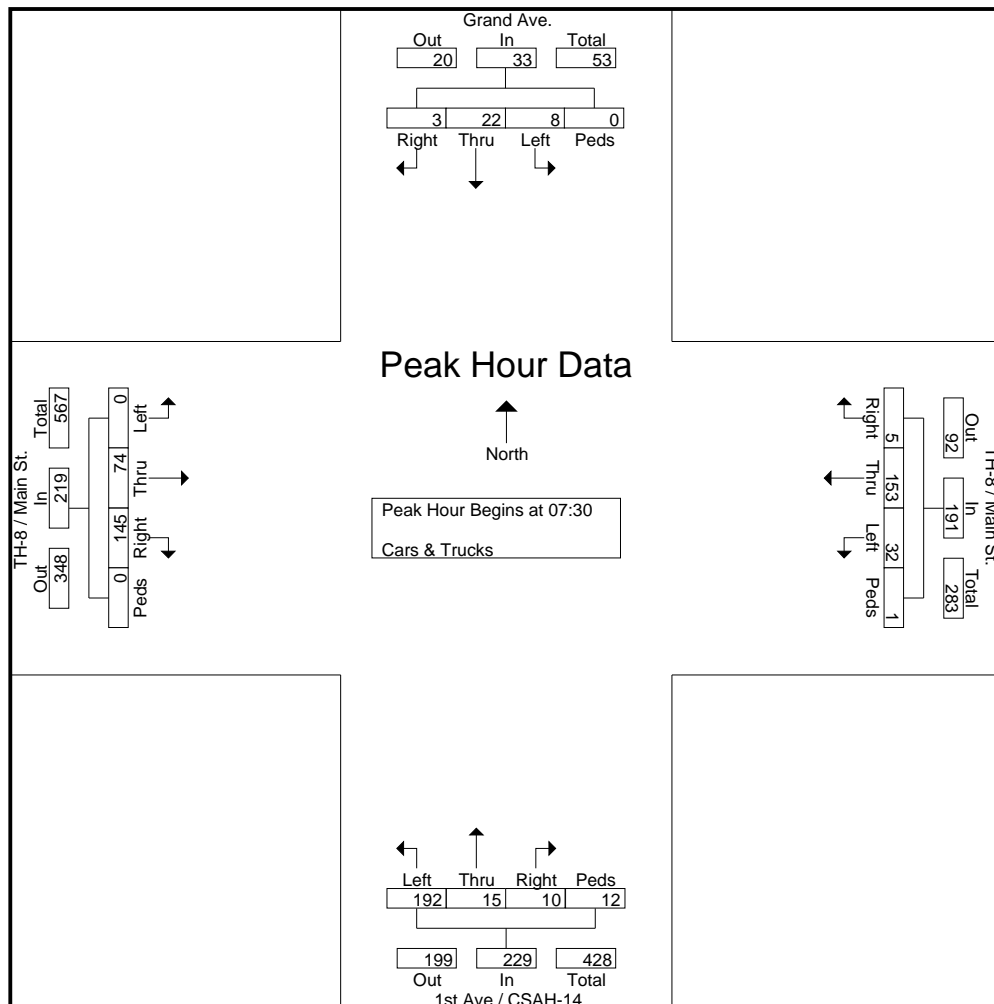



MINNESOTA DEPT OF TRANSPORTATION

TRAFFIC DATA COLLECTION - METRO

TH-8 at 1st Ave / CSAH-14 NORTH BRANCH File Name : TH-8 at CSAH-14 NORTH BRANCH 2009
 Ref.Pt.: 055.543 Site Code : 00000000
 JAMAR #T2582 CR Start Date : 6/10/2009
 TURN MOVEMENT COUNT Page No : 3

Start Time	Grand Ave. Southbound					TH-8 / Main St. Westbound					1st Ave / CSAH-14 Northbound					TH-8 / Main St. Eastbound					Int. Total
	Left	Thru	Right	Peds	App. Total	Left	Thru	Right	Peds	App. Total	Left	Thru	Right	Peds	App. Total	Left	Thru	Right	Peds	App. Total	
Peak Hour Analysis From 15:00 to 17:45 - Peak 1 of 1																					
Peak Hour for Entire Intersection Begins at 17:00																					
17:00	5	7	0	0	12	1	49	3	0	53	51	1	9	1	62	3	65	51	0	119	246
17:15	8	9	2	0	19	1	44	1	0	46	48	3	12	3	66	0	78	52	1	131	262
17:30	8	13	1	0	22	3	51	0	1	55	41	4	10	3	58	1	77	57	0	135	270
17:45	12	9	0	0	21	4	52	0	1	57	50	7	7	2	66	2	72	49	0	123	267
Total Volume	33	38	3	0	74	9	196	4	2	211	190	15	38	9	252	6	292	209	1	508	1045
% App. Total	44.6	51.4	4.1	0		4.3	92.9	1.9	0.9		75.4	6	15.1	3.6		1.2	57.5	41.1	0.2		
PHF	.688	.731	.375	.000	.841	.563	.942	.333	.500	.925	.931	.536	.792	.750	.955	.500	.936	.917	.250	.941	.968

